

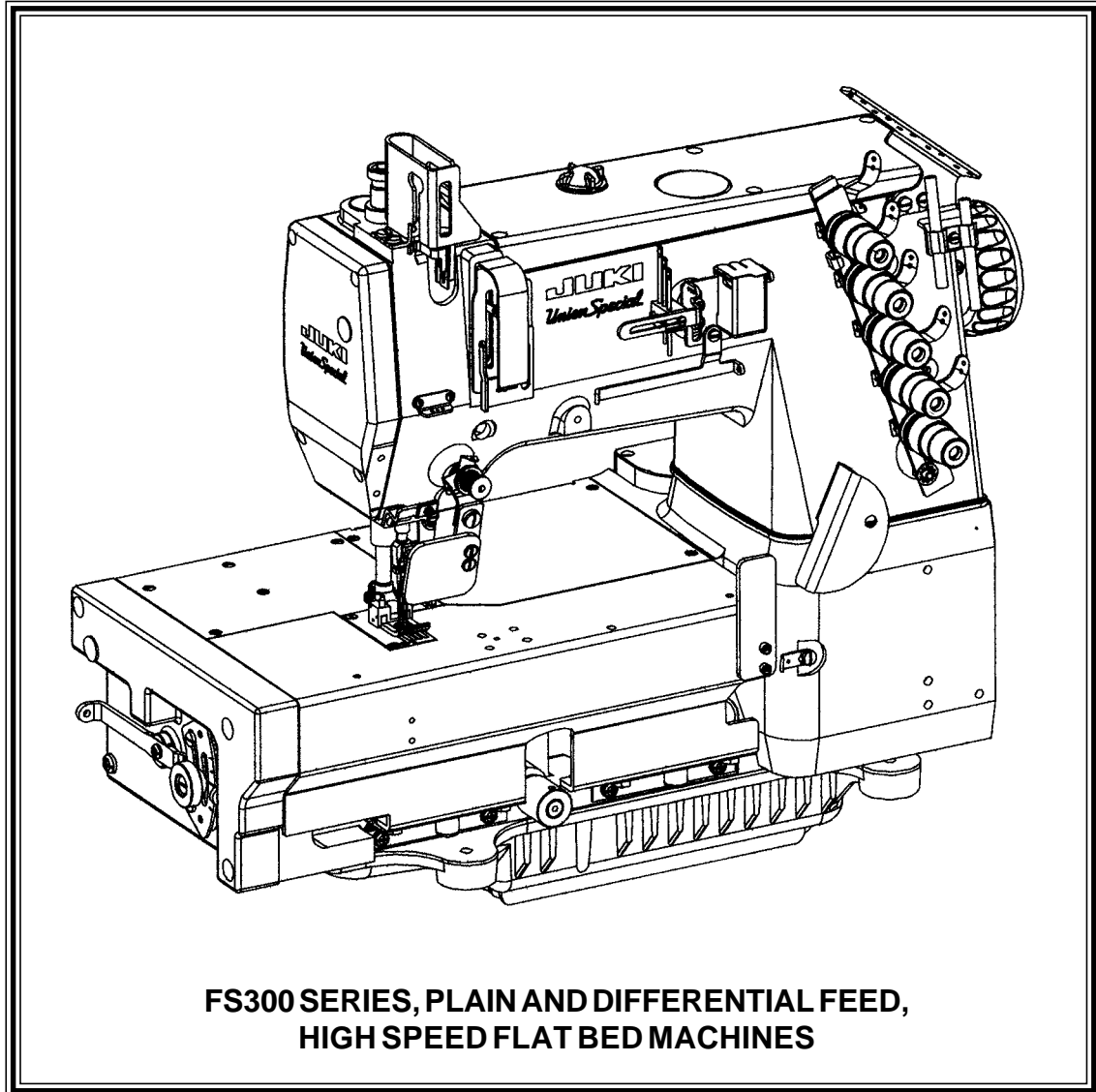

JUKI

Union Special

ILLUSTRATED PARTS MANUAL



**MANUAL NO. PT9800
FOR STYLES**

FS322C01	FS335E42
FS332C01	FS322H01
FS322E12	FS332H01
FS332E12	FS322L01
FS335E41	FS332L21

USE IN CONJUNCTION WITH MACHINE SERIAL NUMBER PREFIX (BG) AND LATER

Manual No. PT9800 Illustrated Parts List for FS300 Series Machines

First Edition Copyright 2000

By

Union Special Corporation Rights Reserved In All Countries

Printed in U.S.A. May 2000

PREFACE

This parts manual has been prepared to assist you in locating individual parts or assemblies on FS300 Series machines. It can be used in conjunction with Union Special Operator's Manual OP9614 and Engineer's Manual EN9424.

It is the desire of Union Special that each machine run at its optimum performance. Parts listed in this manual are designed specifically for your machine and are manufactured with utmost precision to assure long lasting service.

This manual has been comprised on the basis of available information. Changes in design and/or improvements may incorporate a slight modification of configuration in illustrations or part numbers.

On the following pages are illustrations and terminology used in describing the parts used on FS300 Series machines.

Please include part number, name and style of machine for which the part was ordered.

For optimum performance use only genuine Union Special replacement parts.



CONTENTS

PREFACE	2
IDENTIFICATION OF MACHINES	4
STYLE OF MACHINES	4
ILLUSTRATIONS	5
IDENTIFYING PARTS	5
NEEDLES	5
SAFETY RULES	6
BUSHINGS	9
NEEDLE BAR	11
UPPER MAIN SHAFT	13
SPREADER	15
THREAD GUIDE	17
TENSION RELEASE & THREAD TENSION	19
PRESSER FOOT LIFT	21
COVERS, UPPER ARM	23
LOWER MAIN SHAFT	25
LUBRICATION, OIL TUBING & OIL PUMP	27
LOOPER DRIVE	29
NEEDLE GUARD	31
LOOPER THREAD TAKE-UP	33
FEED DRIVE MECHANISM	
FOR FS322C01, FS332CO1, FS322H01, FS332H01, FS332L01, FS332L21	35
FEED DRIVE MECHANISM	
FOR FS322E12 & FS332E12	37
FEED DRIVE MECHANISM	39
COVERS, LOWER BED	41
COVERS, LOWER BED	43
FRONT COVER ASSEMBLY	
FOR FS322C01, FS332C01	45
SEWING PARTS	
FOR FS322C01 & FS332C01	47
SEWING PARTS	
FOR FS322E12 & FS332E12	51
SEWING PARTS	
FOR FS335E41 & FS335E42	53
SEWING PARTS	
FOR FS322H01, FS332H01, FS332L01, FS332L21	57
TABLING AND NEEDLE DIPPER ASSEMBLY (EXTRA SEND CHARGE)	
FOR FS322C01, FS332CO1, FS335E41, FS335E42, FS322H01, FS332H01, FS332L01, FS332L21	59
TABLING (EXTRA SEND CHARGE)	
FOR FS322E12 & FS332E12	61
ACCESSORIES	63
VACUUM TUBE ASSEMBLY AND PNEUMATIC CONTROL (EXTRA SEND CHARGE)	
FOR FS322E12 & FS332E12	65
UNDER BED THREAD TRIMMER	
FOR FS322E12 & FS332E12	67
LOWER ROLLER ASSEMBLY	
FOR FS335E41 & FS335E42	69
UPPER ROLLER ASSEMBLY	
FOR FS335E41 & FS335E42	71
PULLER LIFTER ASSEMBLY	
FOR FS335E41 & FS335E42	73
PULLER DRIVE ASSEMBLY	
FOR FS335E41 & FS335E42	75
NUMERICAL INDEX OF PARTS	76
NUMERICAL INDEX OF PARTS	77
NUMERICAL INDEX OF PARTS	78
NUMERICAL INDEX OF PARTS	79



IDENTIFICATION OF MACHINES

Each UNION SPECIAL machine is identified by a style number, which is stamped into the style plate affixed to the middle of the machine under the tension assembly. The serial number is stamped into the serial number plate affixed to the right rear base of the machine.

STYLE OF MACHINES

- FS322C01- COLLARETTE - Two or three needle, bottom coverstitch. Typical application - For attaching flat of ribbed knit split tube borders to knit garments. Seam specification for two needle 406BSb-1, three needle 407BSb-1. Standard gauges for two needle 32, (1/8", 3.2mm), 40, (5/32", 4.0mm), 48, (3/16", 4.8mm), for three needle 48, (3/16", 4.8mm), 56, (7/32" 5.6mm), 64, (1/4", 6.4mm). Maximum recommended speed, depending on application is up to 6500 R.P.M.
- FS332C01- COLLARETTE - Same as style FS322C01 except top and bottom coverstitch. Seam specification for two needle 602BSb-1, for three needle 605BSb-1.
- FS322E12- ELASTIC - Two or three needle, bottom coverstitch with fabric trimmer. Typical application - For attaching elastic to briefs or lace to lingerie. Seam specification for two needle 406LSa-1, for three needle 407LSa-1. Standard gauges for two needle 32, (1/8", 3.2mm), 40, (5/32", 4.0mm), 48, (3/16", 4.8mm), for three needle 48, (3/16", 4.8mm), 56, (7/32", 5.6mm), 64, (1/4", 6.4mm). Maximum recommended speed, depending on application is up to 6500 R.P.M.
- FS332E12- ELASTIC - Same as Style FS322E12 except top and bottom coverstitch with fabric trimmer. Seam specification for two needle 602LSa-1, for three needle 605LSa-1.
- FS335E41- ELASTIC - Three needle, top and bottom coverstitch, differential feed and rear puller with tooth roller. Typical application - for attaching tunnel elastic to briefs or lace to lingerie. Seam specification 605EFg-1. Standard gauges 56, (7/32", 5.6mm), 64, (1/4", 6.4mm). Maximum recommended speed, depending on application is up to 6000 R.P.M.
- FS335E42- ELASTIC - Same as style FS335E41 except puller with smooth roller.
- FS322H01- HEMMING - Two of three needle, bottom coverstitch. Typical application - for hemming on light to medium weight knit fabrics. Seam specifications for two needle 406EFa-1 (inv.), for three needle 407EFa-1 (inv.). Standard gauge for two needle 40, (5/32" 4.0mm), 48, (3/16", 4.8mm), for three needle 48, (3/16", 4.8mm), 56, (7/32", 5.6mm), 64, (1/4", 6.4mm). Maximum recommended speed, depending on application is up to 6500 R.P.M.
- FS332H01- HEMMING - Same as style FS322H01 except top and bottom coverstitch. Seam specification for two needle 602EFa-1 (inv.), for three needle 605EFa-1 (inv.).
- FS332L01- LAP SEAMING - Two or three needle, top and bottom coverstitch, tandem differential feed. Typical application - for general seaming on fleece and knit garments. Seam specification for two needle 602LSa-1, for three needle 605LSa-1. Standard gauges for two needle 32, (1/8", 3.2mm), 40, (5/32", 4.0mm), for three needle 48, (3/16" 4.8mm), 56, (7/32", 5.6mm), 64, (1/4", 6.4mm). Maximum recommended speed, depending on application is up to 6500 R.P.M.
- FS332L21- LAP SEAMING - Same as style FS332L01 except three needle, off set differential feeds. Standard gauges 56, (7/32", 5.6mm), 64, (1/4"6.4mm).



ILLUSTRATIONS

This manual has been arranged to simplify ordering repair parts. Exploded views of various sections of the mechanism are shown so that the parts may be seen in their actual position in the machine. On the page opposite the illustration will be found a listing of the parts with their part numbers, description and the number of pieces required in the particular view being shown.

Numbers in the first column are reference numbers only, and merely indicate the position of the part in the illustration. The reference number should never be used in ordering parts. Always use the part number listed in the second column.

Component parts of sub-assemblies which can be furnished for repairs are indicated by indenting their descriptions under the description of the main sub-assembly. As an example refer to the following text.

5.	50366B	Needle Thread Strike-Off Assembly	1
6.	50358V	Needle Thread Strike-Off	1
7.	50370F	Thread Strike-Off Component	1
8.	SS7060310SP	Screw, for plate strike-off	1

When a part is common to all machines covered in this manual, no specific usage will be mentioned in the description. However, when the parts for the various machines are not the same, the specific usage will be mentioned in the description and, if necessary, the difference will be shown in the illustration.

*Ref. No. showing no Part No. is for location only. Part is not for sale separately.

A numerical index of all the parts shown in this manual is located at the back. This will facilitate locating the illustration and description when only a part number is known.

IDENTIFYING PARTS

Where construction permits, each part is stamped with its part number. On some of the smaller parts and on those where construction does not permit, an identification letter is stamped in to distinguish the part from similar ones.

PLEASE NOTE: Part numbers represent the same part, regardless of which manual they appear. On all orders

NEEDLES

Each needle has both a type and size number. The type number denotes the kind of shank, point, length, groove, finish and other details. The size number, stamped on the needle shank, denotes the largest diameter of the blade measured between the shank and the eye. Collectively, the type number and size number represent the complete symbol which is given on the label of all needles packed and sold by Union Special.

TYPE

DESCRIPTION

128GBS	Short, double groove, struck groove, ball eye, spotted, ball point, chromium plated- Sizes available 065/025, 070/027, 075/029, 080/032, 090/036.
--------	--

When changing the needle, make sure it is fully inserted in the needle holder before the screw is tightened.

When ordering needles, please use the complete type and size numbers as printed on the package to ensure prompt and accurate processing of your order. A complete order should read as follows: "100 needles, type 128 GBS, size 075/029".



SAFETY RULES

1. Before putting the machines described in this manual into service, carefully read the instructions. The starting of each machine is only permitted after taking notice of the instructions and by qualified operators.

IMPORTANT! Before putting the machine into service, also read the safety rules and instructions from the motor supplier.

2. Observe the national safety rules valid for your country.
3. The sewing machines described in this instruction manual are prohibited from being put into service until it has been ascertained that the sewing units which these sewing machines will be built into, have conformed with the EC Council Directives (89/392/EEC, Annex II B).

Each machine is only allowed to be used as foreseen. The foreseen use of the particular machine is described in paragraph "STYLES OF MACHINES" of this instruction manual. Another use, going beyond the description, is not as foreseen.

4. All safety devices must be in position when the machine is ready for work or in operation. Operation of the machine without the appertaining safety devices is prohibited.
5. Wear safety glasses.
6. In case of machine conversions and changes all valid safety rules must be considered. Conversions and changes are made at your own risk.
7. The warning hints in the instructions are marked with one of these two symbols:

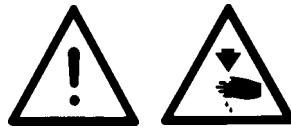

8. When doing the following the machine has to be disconnected from the power supply by turning off the main switch or by pulling out the main plug:
 - 8.1 When threading needle(s), looper, spreader etc.
 - 8.2 When replacing any parts such as needle(s), presser foot, throat plate, looper, spreader, feed dog, needle guard, folder, fabric guide etc.
 - 8.3 When leaving the workplace and when the workplace is unattended.
 - 8.4 When doing maintenance work.
 - 8.5 When using clutch motors without actuation lock, wait until the motor is stopped totally.
9. Maintenance, repair and conversion work (see item 8) must be done only by trained technicians or special skilled personnel under consideration of the instructions.
10. Any work on the electrical equipment must be done by an electrician or under direction and supervision of special skilled personnel.
11. Work on parts and equipment under electrical power is not permitted. Permissible exceptions are described in the applicable sections of standard sheet DIN VDE 0105.
12. Before doing maintenance and repair work on the pneumatic equipment, the machine has to be disconnected from the compressed air supply. In case of existing residual air pressure, after disconnecting from compressed air supply (i.e. pneumatic equipment with air tank), the pressure has to be removed by bleeding.

FS300 SERIES BUILDING BLOCK STYLE DESIGNATION SYSTEM

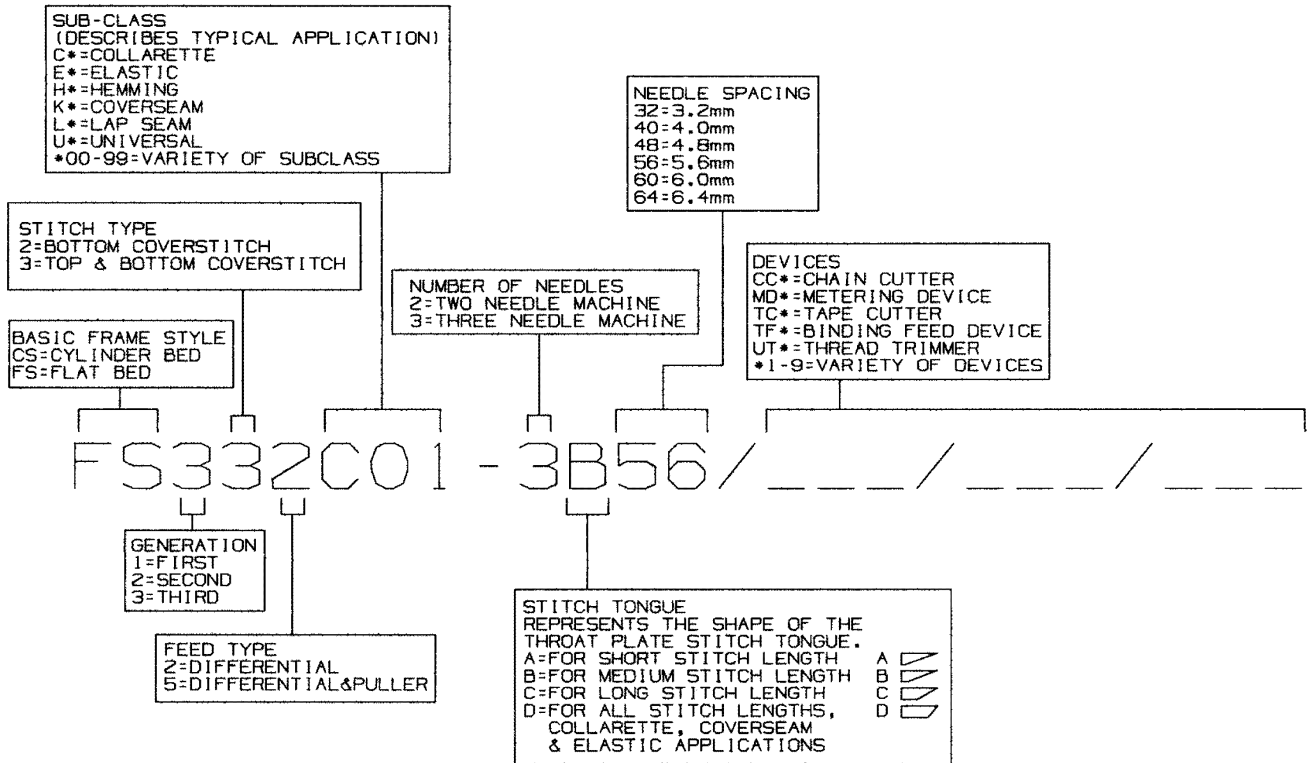

From the library of: Diamond Needle Corp



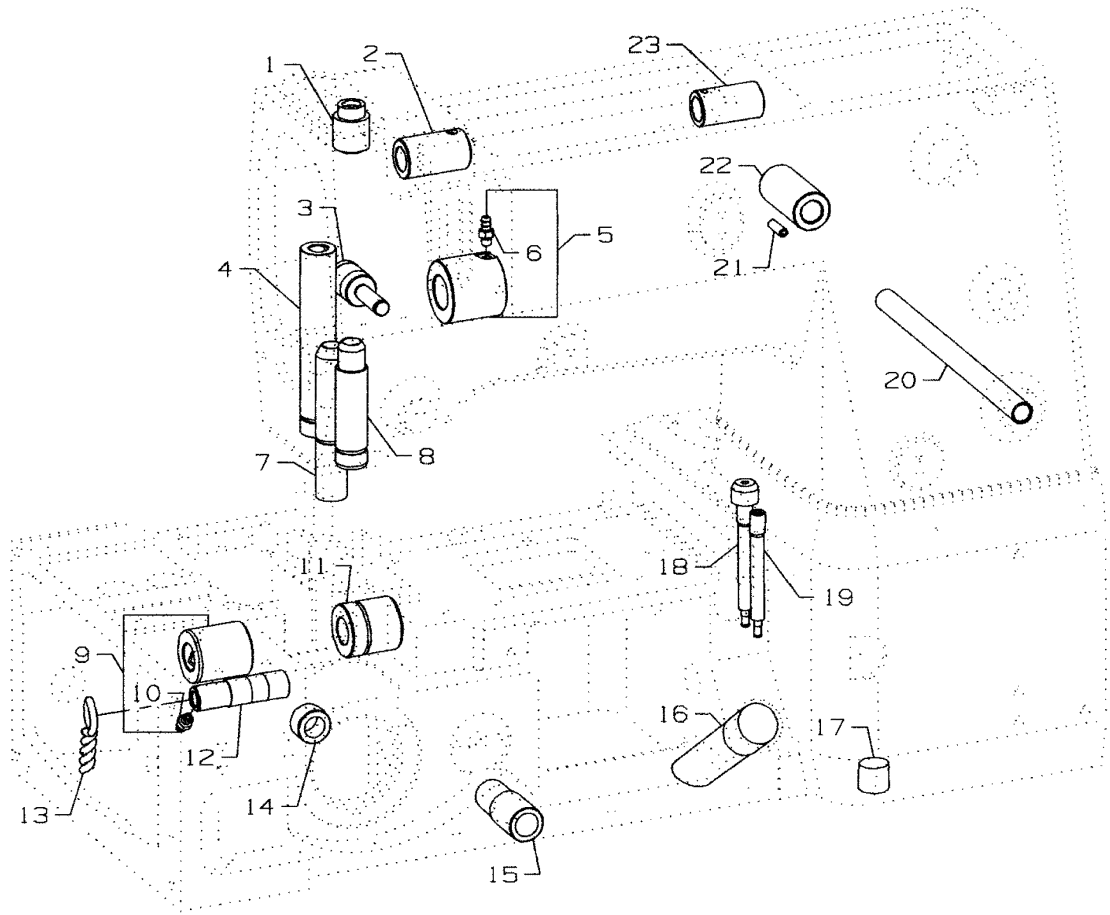

From the library of: Diamond Needle Corp



BUSHINGS

Ref. No.	Part No.	Description	Amt. Req.
1.	50354J	Bushing, for needle bar, upper	1
2.	50347F	Bushing, for spreader, front	1
3.	50332U	Pin, for front lifter lever	1
4.	50347L	Bushing, for spreader drive	1
5.	50344BU	Bushing, front	1
6.	SQ1110401MZ	Fitting	1
7.	50330CZ	Bushing, for presser bar	1
8.	50354H	Bushing, for needle bar, lower	1
9.	50344BE	Bushing, for lower mainshaft, left	1
10.	SQ1110401MZ	Fitting	1
11.	50344BF	Bushing, for lower mainshaft, right	1
12.	50344BC	Bushing, for needle lever	1
13.	CL21A	Oil Wick	1
14.	50344E	Bushing	1
15.	35036AB	Stitch Regulator Bushing	1
16.	50393GE	Oil Sight Gauge	1
17.	22571L	Screw, for drain plug	1
18.	50393EY	Fitting, filter	1
19.	50393FU	Fitting, oil tube	1
20.	50392AB	Bushing, for tension release	1
21.	PS0400142KH	Pin	1
22.	50381E	Bushing, for lifter lever, back	1
23.	50347E	Bushing, for spreader, rear	1

From the library of: Diamond Needle Corp



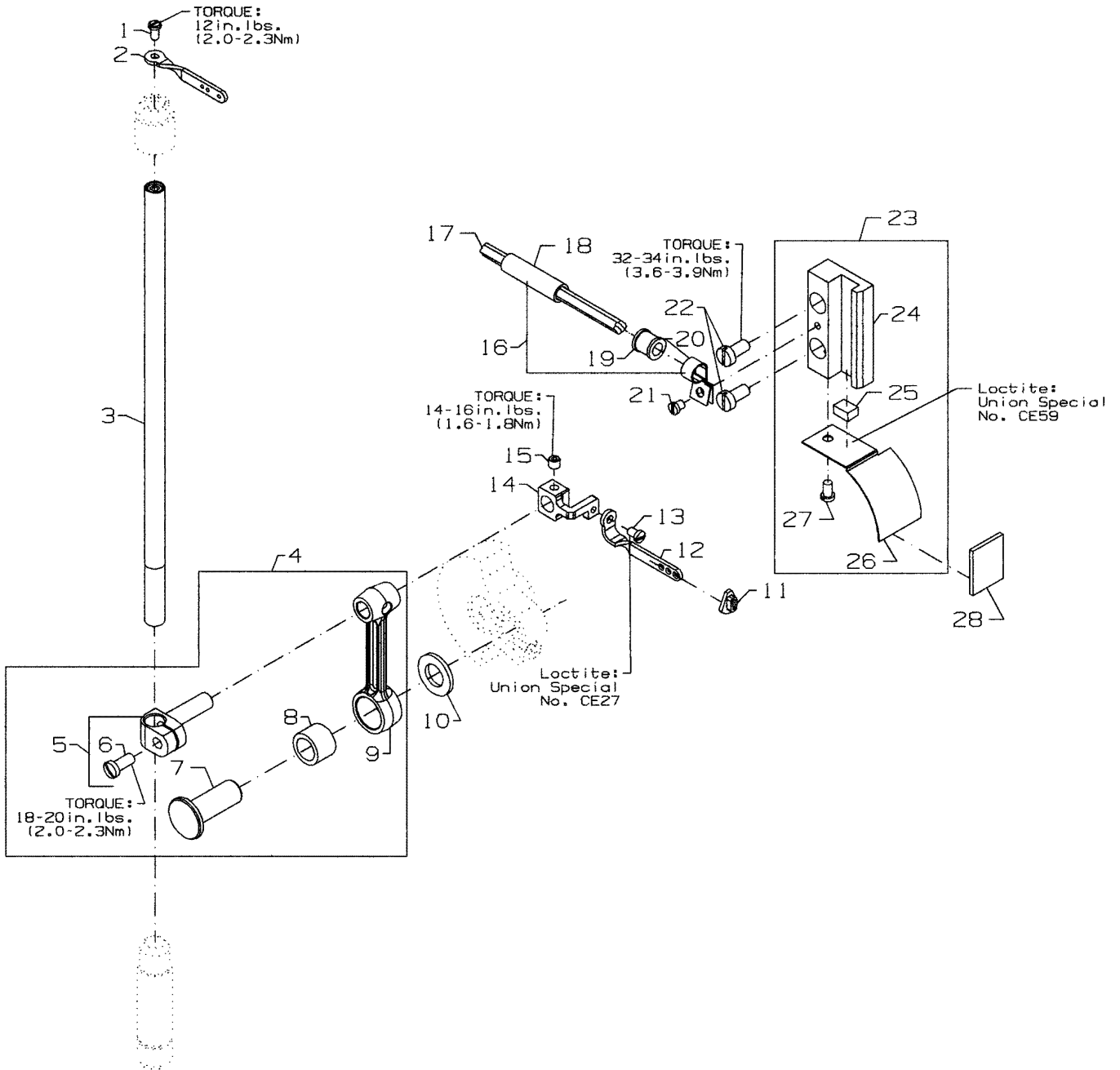

From the library of: Diamond Needle Corp



NEEDLE BAR

Ref. No.	Part No.	Description	Amt. Req.
1.	SS4080620TP	Screw	1
2.	50323P	Needle Bar Eyelet	1
3.	50317B	Needle Bar	1
4.	50345W	Connecting Rod Assembly	1
5.	50355AM	Needle Bar Clamp	1
6.	SS7111120TP	Screw	1
7.	50352	Pivot Pin	1
8.	661-259B	Needle Bearing Cage	1
9.	50355AN	Connecting Rod	1
10.	50351A	Washer	1
11.	50393JP	Eyelet Seal	1
12.	50358X	Needle Thread Eyelet	1
13.	SS7080520SP	Screw	1
-	CE27	Loctite Adhesive, (not shown), for screw	-
14.	50354F	Slide Block	1
-	CE63	Three Bond Adhesive, (not shown), for slide block	-
15.	SS8110422TP	Screw	1
16.	29476TC	Oil Tube Assembly	1
17.	CQ25220000	Cable	1
18.	50393JY	Oil Tube	1
19.	50393JZ	Oil Tube	1
20.	50393JW	Hose Clamp	1
21.	SS6090440SP	Screw, for support bracket	1
22.	SS6121010SP	Screw	2
23.	50354G	Slide Block Guide	1
24.	50393HS	Sponge	1
-	CE59	Loctite Adhesive, (not shown), for sponge	-
25.	50394AF	Slide Block Guide Cover	1
26.	SS6090620SP	Screw	1

From the library of: Diamond Needle Corp



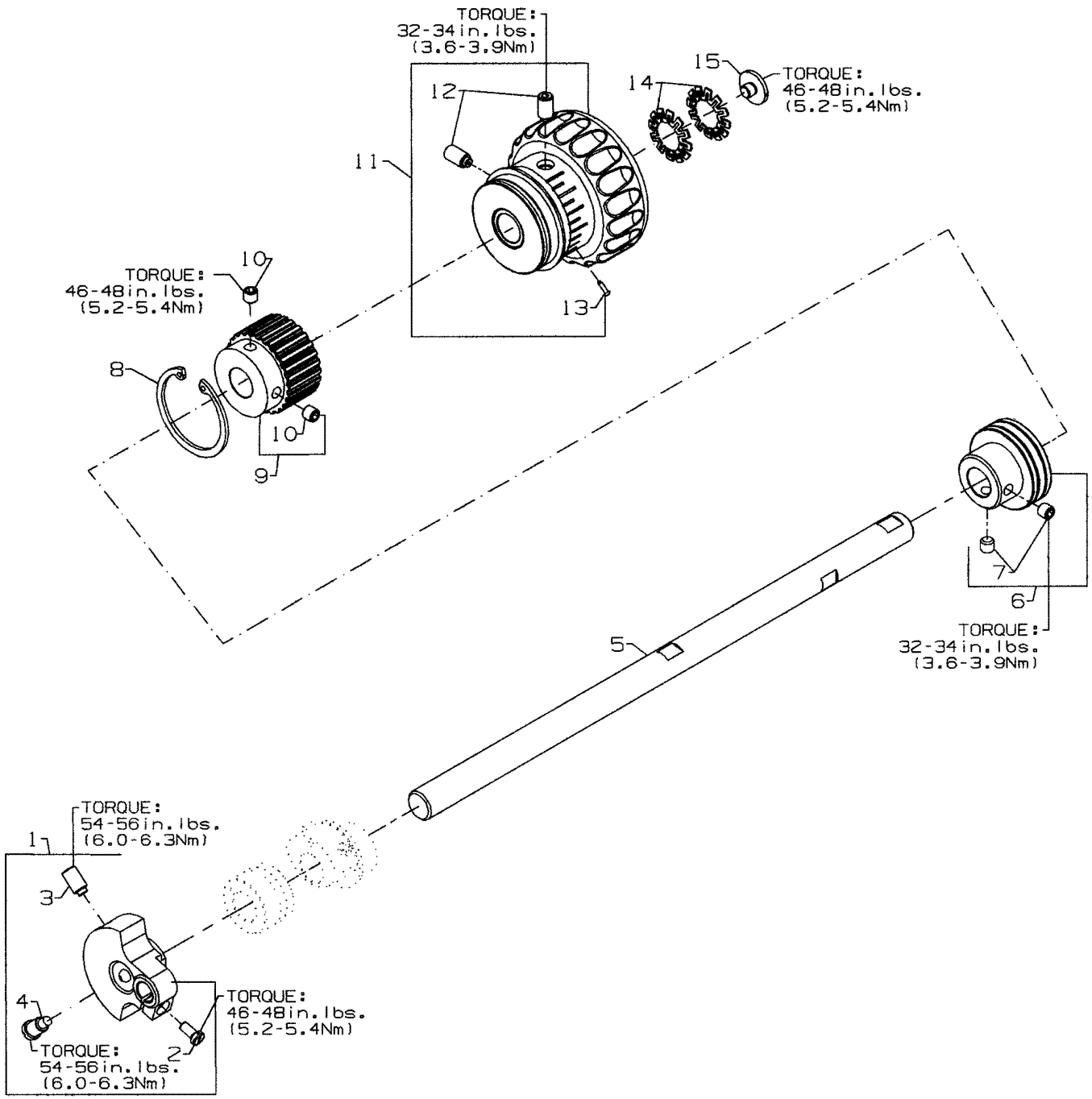

From the library of: Diamond Needle Corp



UPPER MAIN SHAFT

Ref. No.	Part No.	Description	Amt. Req.
1.	50391	Counter Weight	1
2.	SS7111120TP	Screw, for counter weight	1
3.	SS8681412TP	Screw, for counter weight	1
4.	SS7681410TP	Screw, for counter weight	1
5.	50322AF	Upper Main Shaft	1
6.	50335BD	Bearing Adapter Assembly	1
7.	SS8660612TP	Screw, for bearing adapter	2
8.	661-262	Retaining Ring	1
9.	50342BE	Sprocket, for upper main shaft	1
10.	SS8661012TP	Set Screw, for sprocket	2
11.	50321M	Handwheel	1
12.	SS8681412TP	Set Screw, for handwheel	2
13.	660-1043	Tack Pin, for handwheel	1
14.	661-261	Load Ring, for lower main shaft	2
15.	SS7660520SP	Screw, for handwheel preload	1

From the library of: Diamond Needle Corp



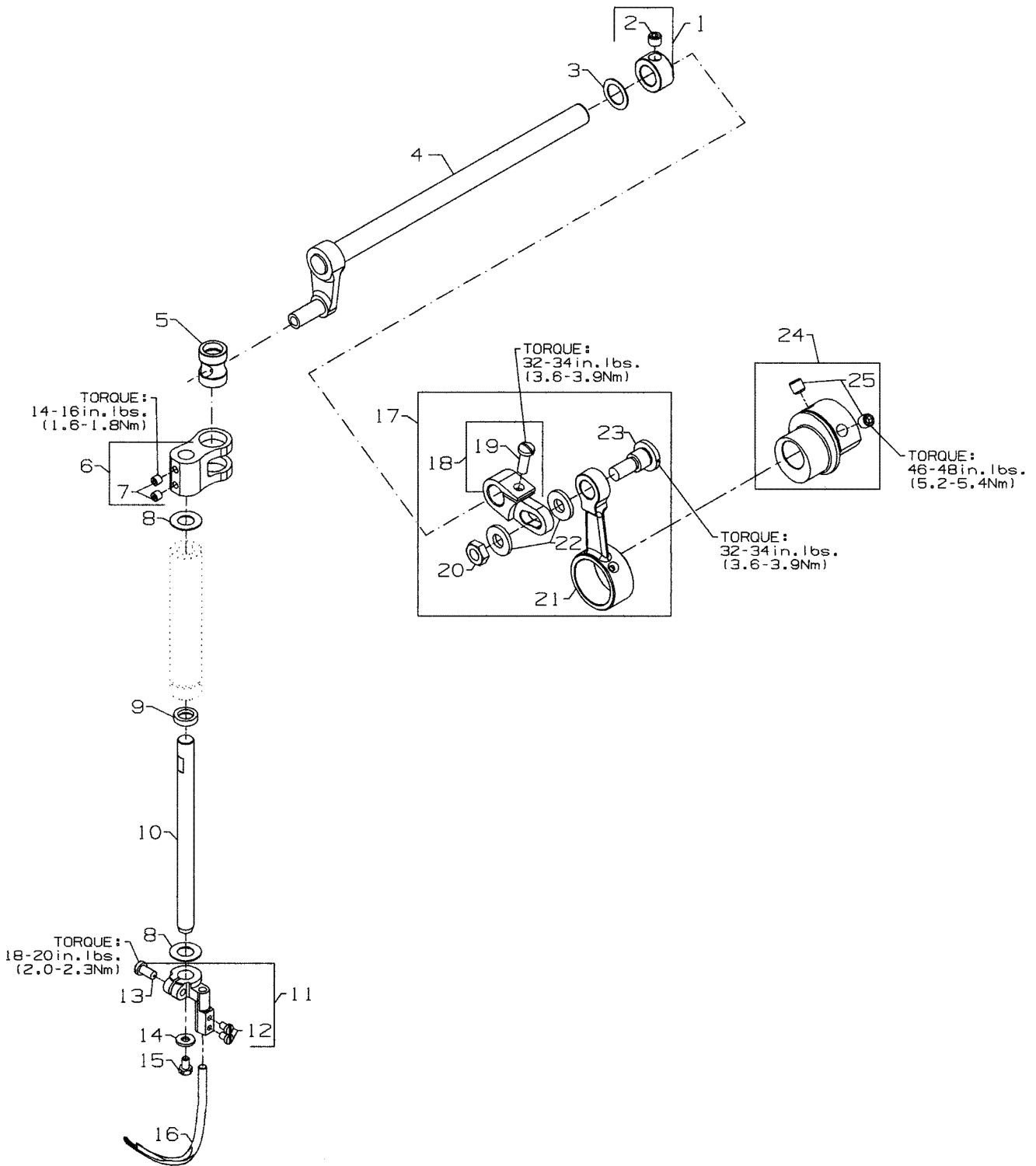

SPREADER

Ref. No.	Part No.	Description	Amt. Req.
1.	50335AW	Collar, for spreader shaft	1
2.	SS8660512TP	Set Screw	1
3.	96162B	Washer	1
4.	50360B	Crankshaft, for spreader assembly	1
5.	50347J	Pin, for spreader rocker	1
6.	50347C	Lever, for spreader holder shaft	1
7.	SS8110422TP	Screw	2
8.	61351C	Washer	2
9.	660-739	Oil Seal	1
10.	50347G	Shaft, for spreader, vertical	1
11.	50346A	Spreader Holder	1
12.	SS7080510TP	Screw	2
13.	SS7110910TP	Screw	1
14.	53678N	Washer	1
15.	SS9090640SP	Hex Screw, for vertical shaft	1
16.	50360H	Spreader	1
17.	29126FW	Spreader Crank Rod Assembly	1
18.	50360G	Spreader Shaft Driving Arm	1
19.	SS7121410TP	Screw	1
20.	NS6680410SP	Hex Nut, for spreader drive	1
21.	50360F	Connecting Rod, for spreader drive	1
22.	WP0742016SP	Collar, for spreader driving arm	2
23.	SD1000801SH	Stud	1
24.	50360	Eccentric, for spreader drive	1
25.	SS8660612TP	Screw	2

From the library of: Diamond Needle Corp



THREAD GUIDE

Ref. No.	Part No.	Description	Amt. Req.
1.	SS7120640SP	Screw, for lead-in eyelet	2
2.	50392AU	Thread Eyelet Assembly	1
3.	SS7090910TP	Screw	1
4.	WS0510002KP	Split Washer	1
5.	50366A	Thread Eyelet Tube Bracket	1
6.	50392S	Lead-In Tension Eyelet	1
7.	50366	Thread Eyelet Tube	2
8.	SS4120615SP	Screw, for needle thread guide	2
9.	50363CK	Needle Thread Guide and Lubricator Assembly	1
10.	SS7110410SP	Screw, for spreader thread guide	1
11.	50358U	Thread Guide, for spreader	1
12.	50393HH	Silicone Thread Lubricator	1
13.	WP0371026SD	Washer	2
14.	50366J	Needle Thread Guide	1
15.	SS7080510TP	Screw, for holder eyelet	1
16.	SS4090815SP	Screw, for silicone tank	2
17.	50358W	Holder, for needle thread eyelet	1
18.	SS8080410TP	Screw	3
19.	36271A	Adjusting Needle Thread Eyelet	3
20.	SS7120710SP	Screw, for strike-off	1
21.	50366B	Needle Thread Strike-Off Assembly	1
22.	SS7060310SP	Screw, for plate strike-off	1
23.	50370F	Thread Strike-Off Component	1
24.	50358V	Needle Thread Strike-Off	1
25.	50392T	Eyelet	1
26.	605A	Screw, for needle thread guide	2
27.	C50044E	Needle Thread Guide	1
28.	SS7090610SP	Screw	1
29.	12124202	Looper Frame Eyelet	1
30.	29475CG	Spreader Thread Tension Assembly	1
31.	50392AZ	Tension Nut	1
32.	50392AY	Tension Spring	1
33.	50392AX	Tension Disc	2
34.	50392AW	Tension Post	1
35.	57844	Eyelet	1
36.	652C16	Star Washer	1
37.	SS7120640SP	Screw	1
38.	50392AE	Looper Frame Eyelet	1
39.	SS1121010SP	Screw, for thread guide	1
40.	50357AR	Nipper Plate Assembly	1
41.	SD0380551SL	Screw	1
42.	50357AS	Nipper Spring	1
43.	50357Y	Nipper Spring Plate	1
44.	50357V	Nipper Plate	1
45.	50366G	Thread Guide	1
46.	SS7090610SP	Screw, for spreader thread guide	2
47.	50346	Thread Guide Spreader	1

From the library of: Diamond Needle Corp



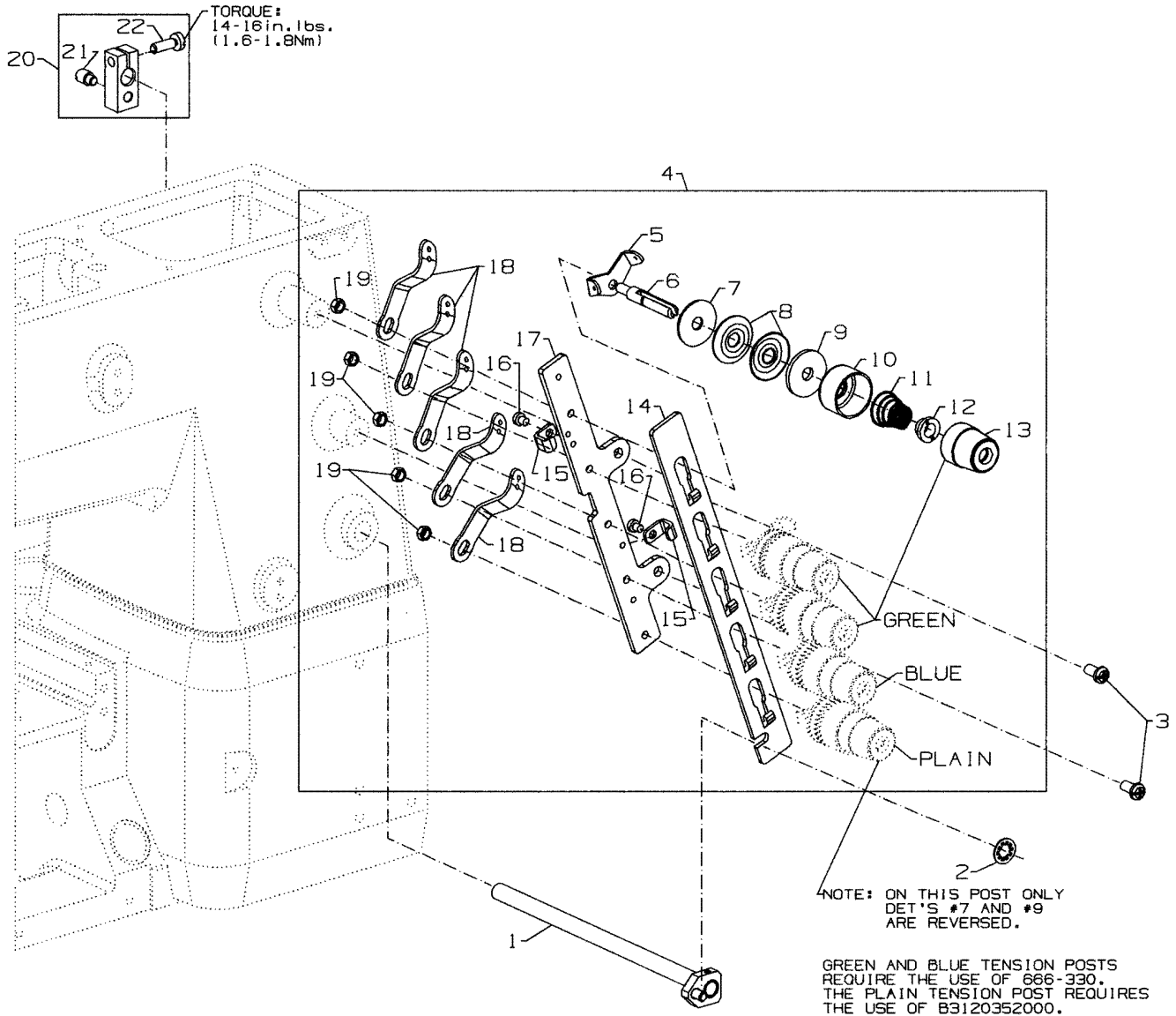

TENSION RELEASE & THREAD TENSION

Ref. No.	Part No.	Description	Amt. Req.
1.	50392Z	Tension Needle Lever Assembly	1
2.	660-283A	Retainer Washer	1
3.	SS4120915SP	Screw, for tension assembly	2
4.	50392Y	5 Thread Tension Assembly	1
5.	57892K	Thread Tension Eyelet	5
6.	56392G	Tension Post	5
7.	B3120352000	Tension Disc Felt	1
-	666-330	Disc Felt	4
8.	B3126012000	Tension Disc	10
9.	B3120704000	Tension Disc Felt	5
10.	56392H	Spring Shield	5
11.	11550209	Spring, needle (green)	3
-	B3103804000	Spring, spreader (blue)	1
-	B3121804000	Spring, looper (plain)	1
12.	B3112704000	Ferrule, tension spring	5
13.	50692G	Knob, needle (green)	3
-	56392M	Knob, spreader (blue)	1
-	56392R	Knob, looper (plain)	1
14.	50392W	Tension Disc Separator	1
15.	50392AV	Guide, for tension disc separator	2
16.	SS7090520SP	Screw, for guide	2
17.	50392X	Tension Bracket	1
18.	57865	Lead-In Thread Guide	5
19.	NS6110420SP	Nut	5
20.	50392BC	Tension Release Lever Shaft Connection	1
21.	22875N	Base Spring Screw	1
22.	SS7121410TP	Binder Screw	1

From the library of: Diamond Needle Corp



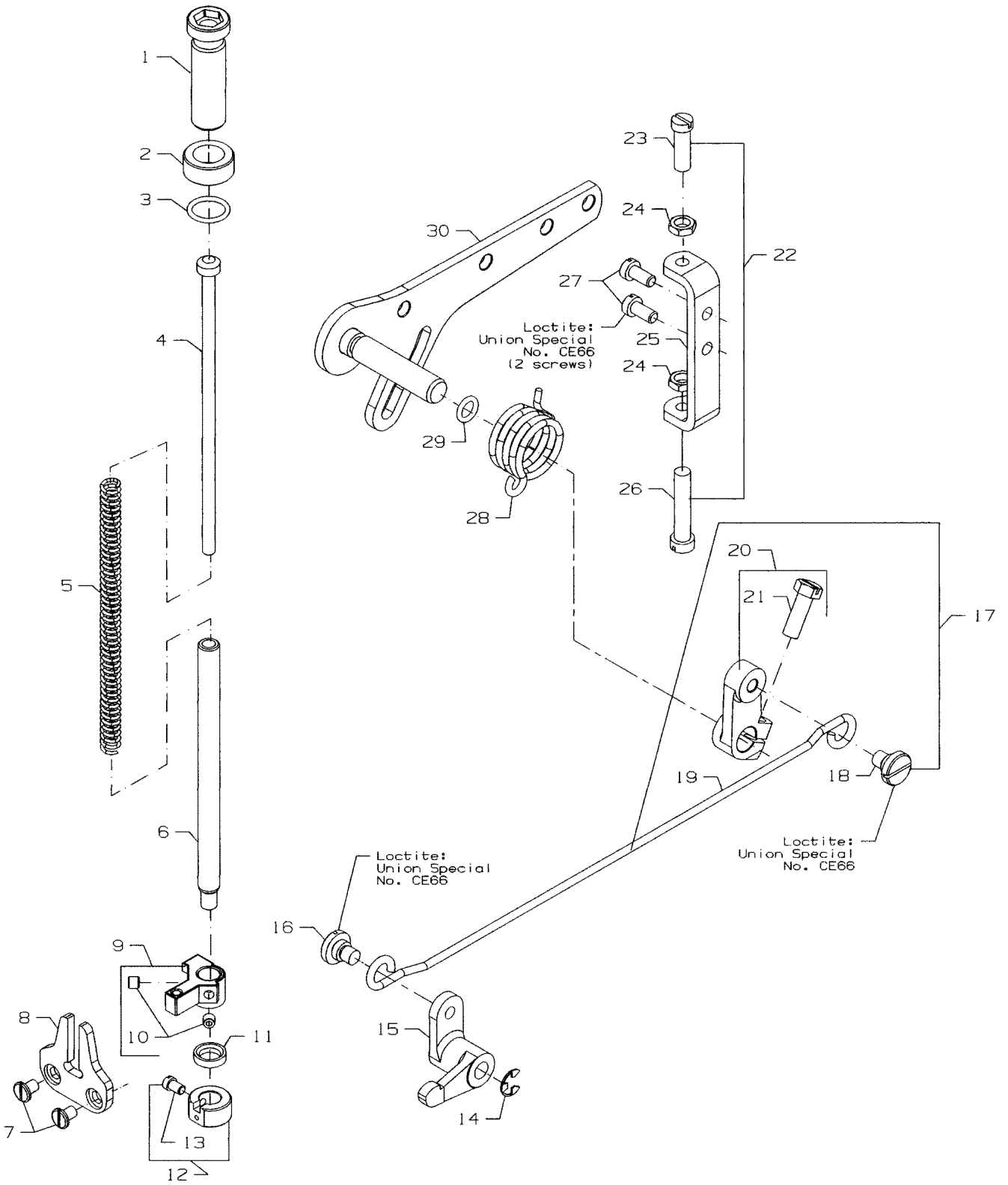

PRESSERFOOTLIFT

Ref. No.	Part No.	Description	Amt. Req.
1.	11071602	Adjusting Screw, for spring	1
2.	11071701	Locking Nut	1
3.	660-1014	"O" Ring	1
4.	C50056B	Spring Rod	1
5.	50357AP	Spring, for presser bar	1
6.	50335AF	Presser Bar	1
7.	SS6110610TP	Screw, for guide plate	2
8.	50335AG	Guide Plate, for presser bar	1
9.	50335AH	Presser Bar Guide	1
10.	SS8110422TP	Set Screw	2
11.	660-739	Oil Seal	1
12.	50333P	Collar	1
13.	22562	Screw	2
14.	RE0500000K0	E Ring, for pin	1
15.	50381F	Lever, for lifter, front	1
16.	SD0790303SP	Screw, for wire connector	1
-	CE66	Loctite Adhesive, (not shown), for screw	-
17.	29476TK	Rear Lifter Lever Assembly	1
18.	SD0790303SP	Screw	1
19.	50355AR	Wire Connector	1
20.	50381G	Lifter Lever, rear	1
21.	SS9151740CP	Hex Screw	1
22.	29476TT	Stop Assembly	1
23.	SS6121010SP	Screw, for stopper	1
24.	NS6150310SP	Hex Nut	2
25.	50332V	Stopper, for lifter lever	1
26.	SS6153040SP	Screw, for adjusting stopper	1
27.	SS6151920SP	Screw, for adjusting stopper	2
-	CE66	Loctite Adhesive, (not shown), for screw	-
28.	50381	Spring, for lifter lever	1
29.	RO068190100	"O" Ring	1
30.	50381B	Lifter Lever Assembly	1

From the library of: Diamond Needle Corp



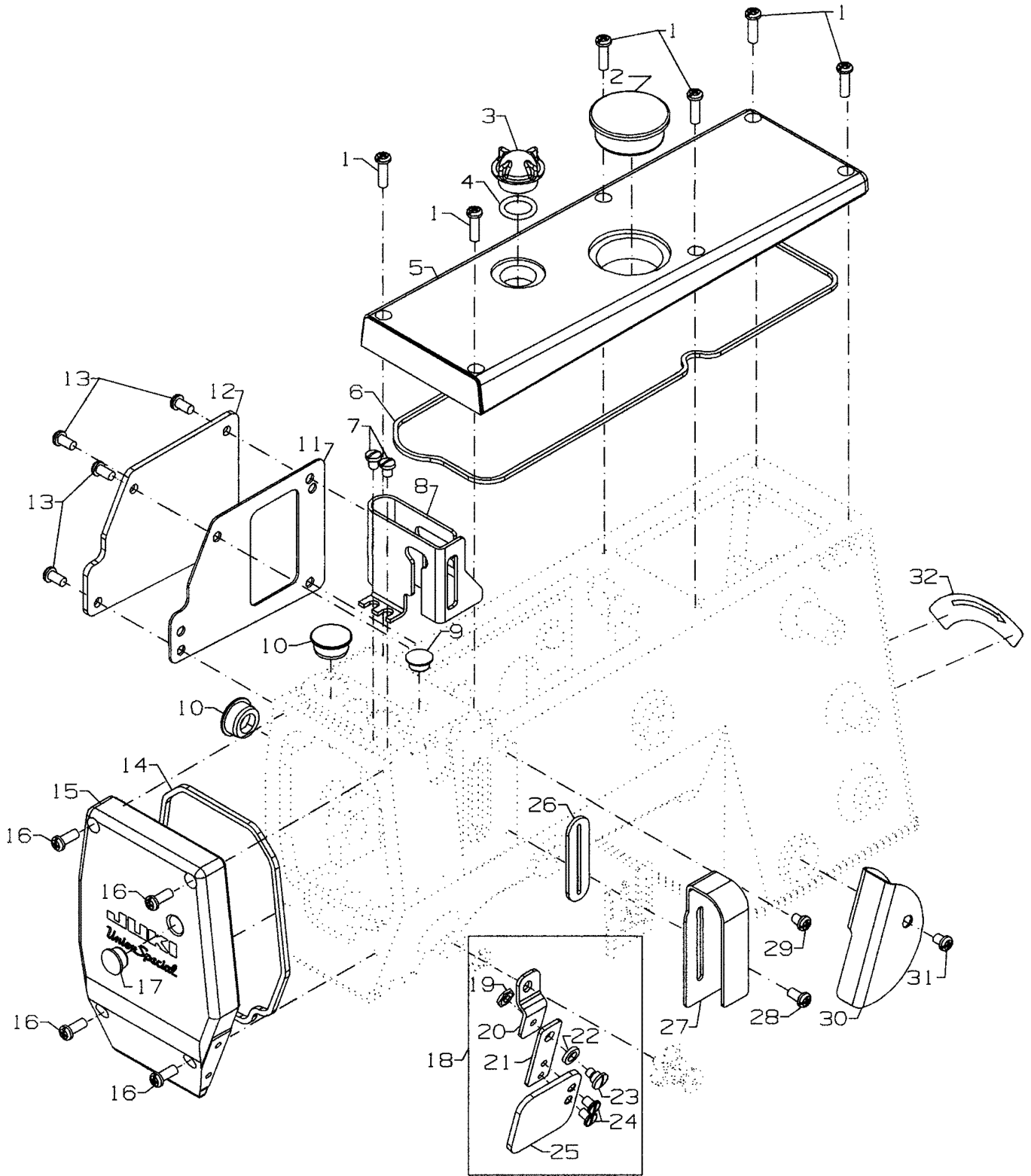

COVERS, UPPER ARM

Ref. No.	Part No.	Description	Amt. Req.
1.	SS4121615SP	Screw, for top cover	6
2.	50393EU	Plug, for top cover	1
3.	B3530555000	Oil Sight Gauge, top	1
4.	660-212	"O" Ring, for oil sight gauge	1
5.	50382FW	Top Cover	1
6.	50382FZ	Quad Ring, for top cover	1
7.	SS7120640SP	Screw, for needle bar guard	2
8.	50317C	Needle Bar Guard	1
9.	TA1050504R0	Plug, for bed	1
10.	50393HB	Plug, for bed	2
11.	50384L	Gasket, for puller drive cover	1
12.	50382GB	Puller Drive Cover	1
13.	SS4120915SP	Screw, for puller drive cover	4
14.	50382FY	Quad Ring, for head cover	1
15.	50382FX	Head Cover	1
16.	SS4121215SP	Screw, for head cover	4
17.	TA1100604R0	Plug, for head cover	1
18.	99682XCB	Protection Shield Assembly, for all styles except FS322E12 & FS332E12	1
19.	NS6620320SP	Nut	1
20.	50383AE	Bracket Holder	1
21.	50383AD	Bracket	1
22.	WZ0641510KP	Spring Washer	1
23.	SD0640323TP	Shoulder Screw	1
24.	SS6110610SL	Counter Sunk Head Screw	2
25.	99682XC3	Protection Shield	1
26.	50393EW	Rubber Gasket, for needle lever	1
27.	50382GA	Cover, for thread take-up	1
28.	SS4120915SP	Screw, for thread take-up cover	1
29.	SS4120615SP	Screw, for thread cover	1
30.	50382GM	Thread Cover	1
31.	SS4120615SP	Screw, for thread take-up cover	1
32.	LA452	Label, direction of rotation	1

From the library of: Diamond Needle Corp



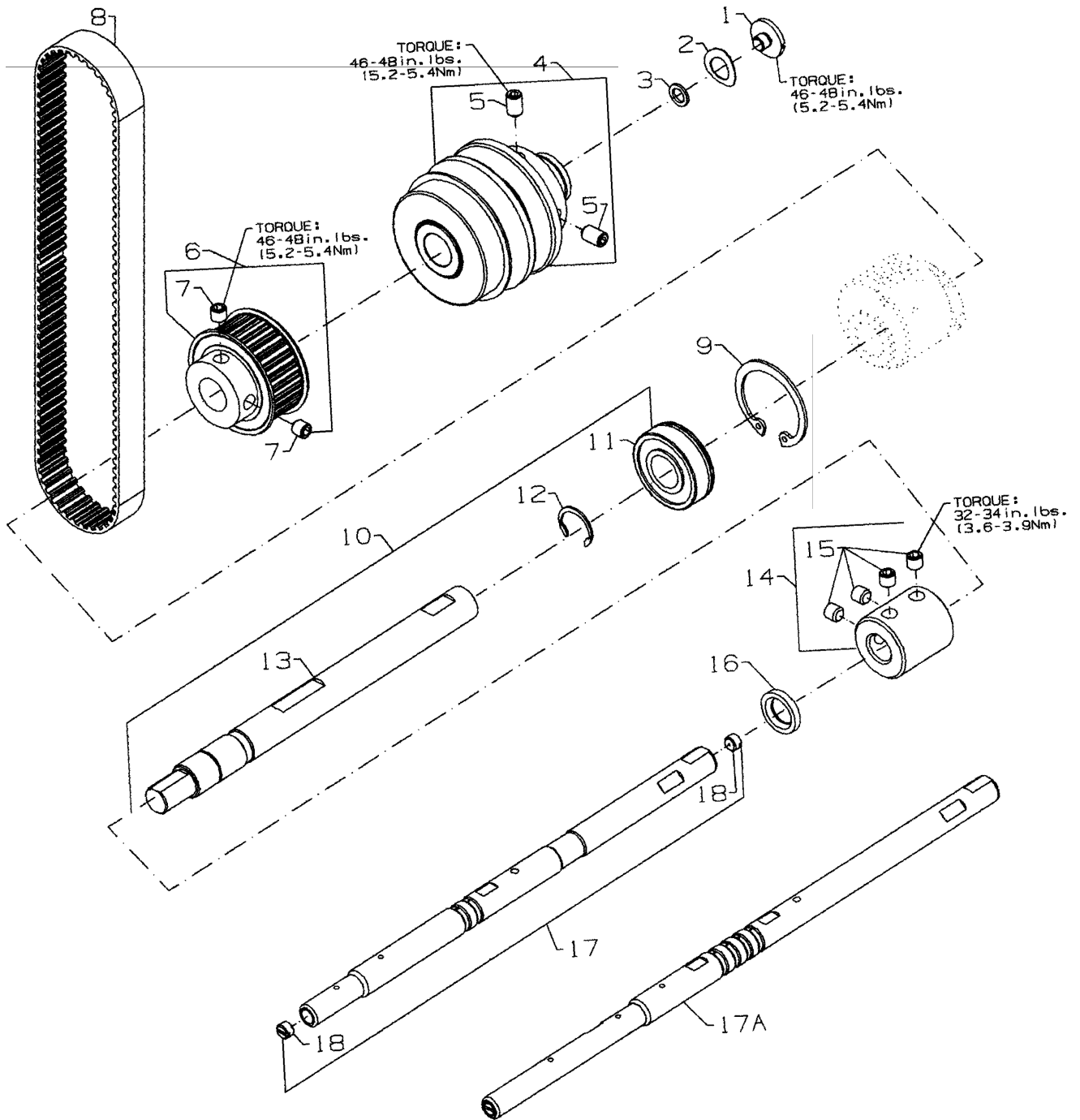

LOWER MAIN SHAFT

Ref. No.	Part No.	Description	Amt. Req.
1.	SS7660520SP	Shoulder Screw, for lower main shaft, right	1
2.	660-1062	Spring Washer	1
3.	50374	Spacer, for pulley assembly	1
4.	50321G	Pulley Assembly	1
5.	SS8661012TP	Set Screw	2
6.	50342AX	Sprocket, for lower main shaft	1
7.	SS8660612TP	Screw	2
8.	50342BS	Timing Belt	1
9.	50335AK	Retaining Ring, for ball bearing	1
10.	29476UH	Mainshaft Assembly, lower right	1
11.	50322AL	Ball Bearing, for lower main shaft	1
12.	50335BB	Retaining Ring	1
13.	50322AG	Lower Main Shaft, right	1
14.	50333A	Coupling, for lower main shafts	1
15.	SS8660612TP	Screw	4
16.	660-934	Oil Seal	1
17.	50322AU	Lower Main Shaft, left	1
17A.	50322AT	Lower Main Shaft, left, for FS322E12, FS332E12	1
18.	SS8660410SP	Screw	2

From the library of: Diamond Needle Corp



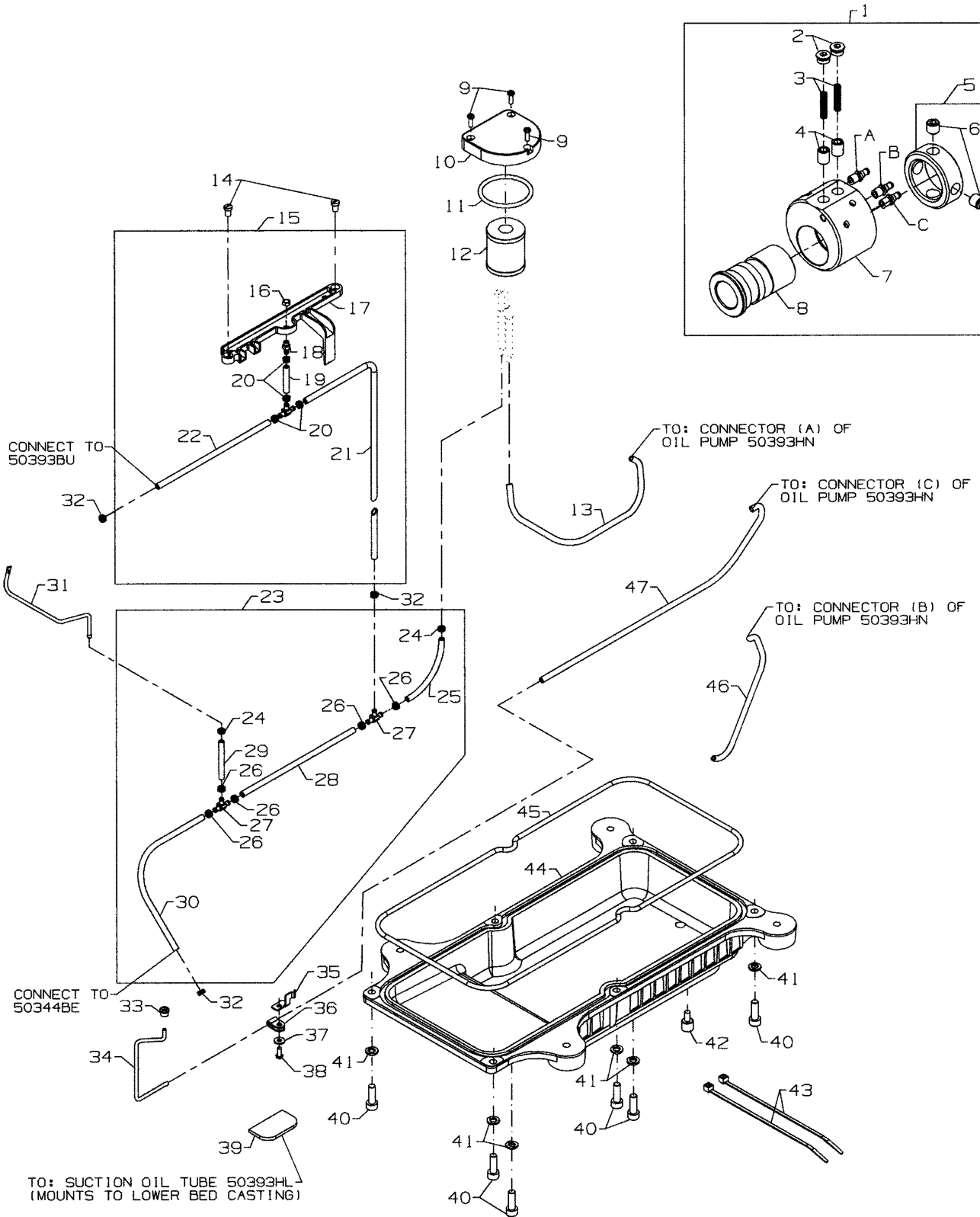

LUBRICATION, OIL TUBING & OIL PUMP

Ref. No.	Part No.	Description	Amt. Req.
1.	50393HN	Oil Pump Assembly, 2-stage	1
2.	18-1470	Screw	2
3.	50332S	Spring, for plunger.....	2
4.	34393D	Plunger	2
5.	50393EX	Collar, for oil pump	1
6.	SS8660612TP	Screw	2
7.	50393GB	Oil Pump Housing, 2 Stage.....	1
8.	50393GD	Oil Pump Housing, 2 Stage.....	1
9.	SS4091015SP	Screw, for oil filter cover.....	3
10.	50393FR	Cover, for oil filter.....	1
11.	50384	"O" Ring, for oil filter cover.....	1
12.	11843208	Oil Filter.....	1
13.	50393FV	Oil Tube, for supply (1)	1
14.	SS7120710SP	Screw	2
15.	29476US	Oil Supply Assembly, upper	1
16.	NS6110310SP	Nut	1
17.	50393KC	Oil Gutter	1
18.	SQ1110402MZ	Fitting	1
19.	50393-27	Oil Tube	1
20.	50393KM	Tube Retaining, spring	4
21.	50393-407	Oil Tube	1
22.	50393-140	Oil Tube	1
23.	29476UT	Oil Supply Assembly, lower	1
24.	50393KH	Tube Retaining, spring	2
25.	50393-70	Oil Tube	1
26.	50393KM	Tube Retaining, spring	5
27.	13765607	"T" Connector	2
28.	50393-140	Oil Tube	1
29.	50393-40	Oil Tube	1
30.	50393-170	Oil Tube	1
31.	50393KF	Oil Tube	1
32.	50393KM	Tube Retaining, spring	3
33.	50393HR	Plug, for feed chamber	1
34.	50393HL	Oil Tube, for suction	1
35.	50393FS	Oil Tube Holder	1
36.	998-358F	Plastic Clip	1
37.	53678N	Washer	1
38.	SS4090815SP	Screw, for oil tube holder	1
39.	50393HK	Felt	1
40.	SS6151812TP	Screw, for oil pan	6
41.	WS0631510KP	Spring Washer	6
42.	22571E	Screw, for oil drain plug	1
43.	RM2871B	Cable Tie	2
44.	50393EB	Oil Pan	1
45.	50384A	"O" Ring	1
46.	50393FT	Oil Tube, for suction	1
47.	50393HJ	Oil Tube, for suction	1

From the library of: Diamond Needle Corp



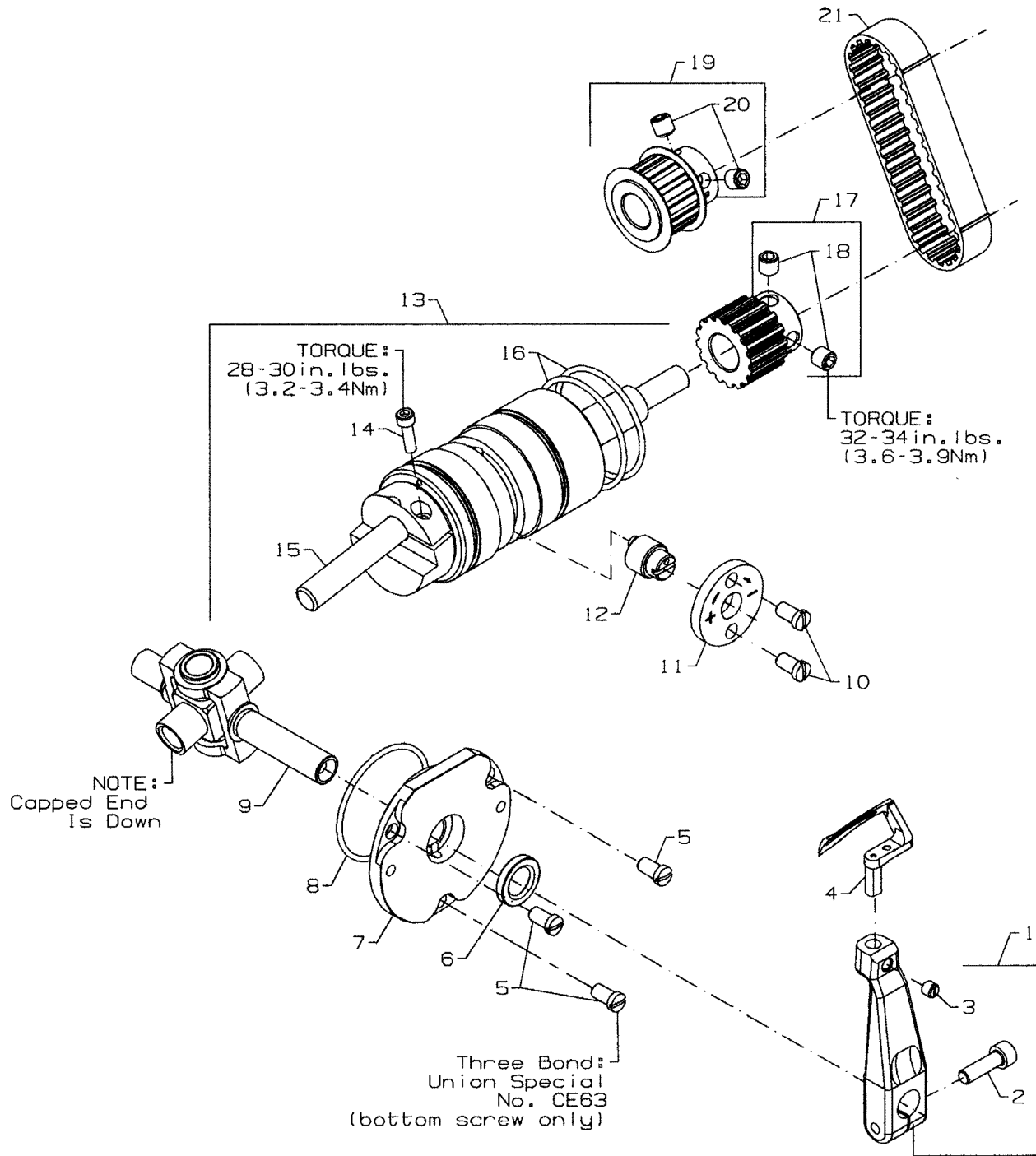

LOOPER DRIVE

Ref. No.	Part No.	Description	Amt. Req.
1.	50313P	Looper Holder	1
2.	22652B10	Screw, for looper holder	1
3.	22565	Screw, for looper holder	1
4.	50309K	Looper	1
5.	SS7120910SP	Screw, for bearing housing	3
-	CE63	Three Bond Adhesive, (not shown), for screw	-
6.	660-893	Oil Seal, looper	1
7.	50344AM	Bearing Housing Assembly, for looper drive	1
8.	660-455	"O" Ring, for bearing housing assembly	1
9.	50313J	Looper Rocker Assembly	1
10.	SS7120910SP	Screw, for retaining plate	2
11.	50314J	Eccentric Retaining Plate	1
12.	50314E	Looper Avoid Adjusting Eccentric.....	1
13.	50313M	Looper Drive Assembly	1
14.	22653J8	Screw	1
15.	667J33	Crank Pin	1
16.	660-979	"O" Ring	2
17.	50342BJ	Sprocket, for looper driven	1
18.	SS8660612TP	Screw	2
19.	50342BK	Sprocket, for looper drive	1
20.	SS8660612TP	Screw	2
21.	50342BP	Looper Drive Belt	1

From the library of: Diamond Needle Corp



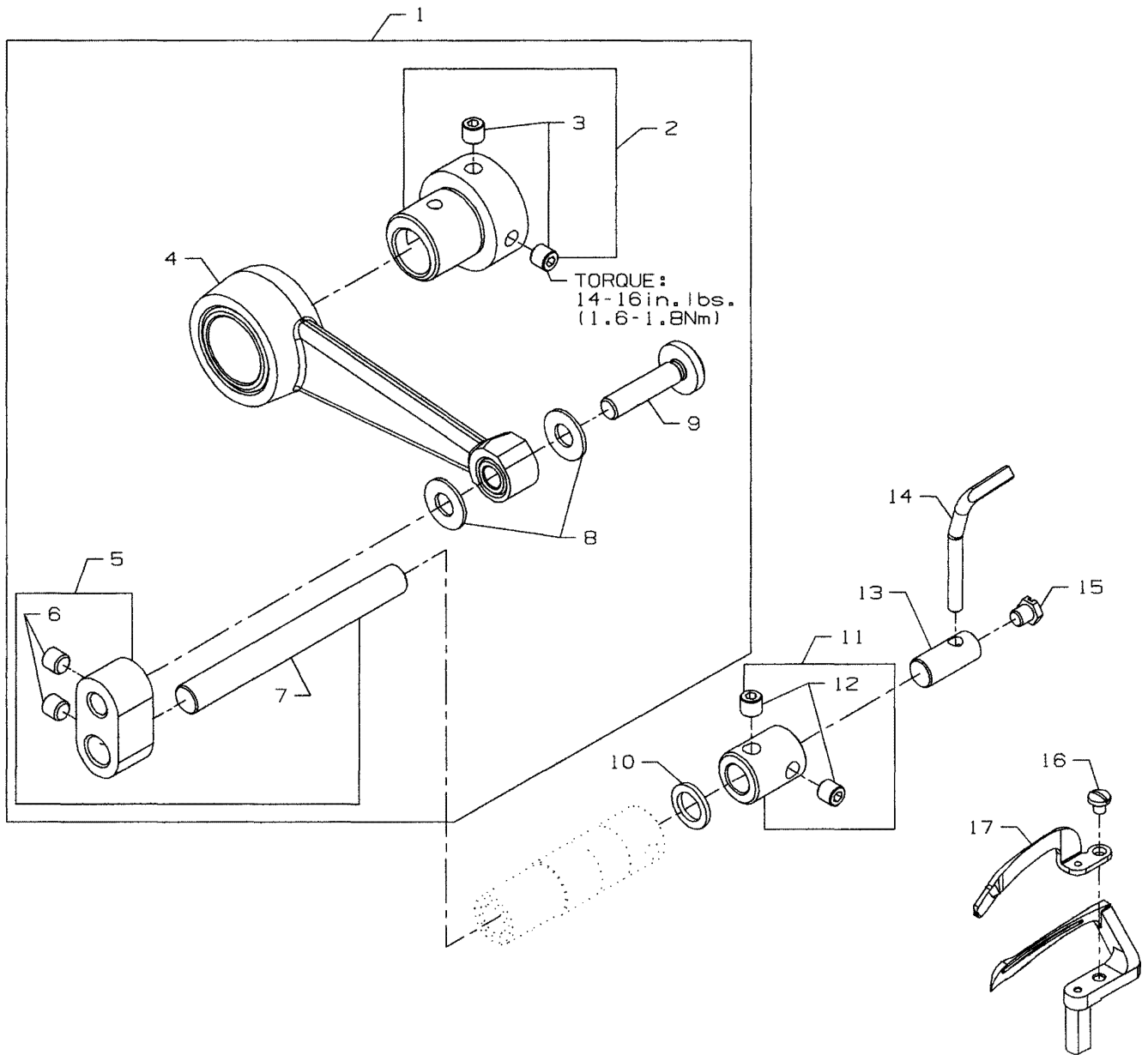

From the library of: Diamond Needle Corp



NEEDLE GUARD

Ref. No.	Part No.	Description	Amt. Req.
1.	29476UJ	Rear Needle Guard Drive Assembly	1
2.	50373DA	Needle Guard Eccentric	1
3.	SS8110422TP	Screw, for needle guard eccentric	2
4.	50368W	Connecting Rod Assembly, for needle guard	1
5.	50368T	Pivot Link	1
6.	SS8110422TP	Screw	2
7.	50368V	Shaft, for needle guard	1
8.	50368E	Washer	2
9.	50368A	Pivot Pin	1
10.	50374	Washer	1
11.	50354L	Coupling, for needle guard	1
12.	SS8110422TP	Screw	2
13.	50325AF	Holder, for needle guard	1
14.	50325AE	Needle Guard, rear	1
15.	SS9090420TP	Screw, for rear needle guard	1
16.	SS7060310SP	Screw, for front needle guard	1
17.	50325AJ	Needle Guard, front	1

From the library of: Diamond Needle Corp



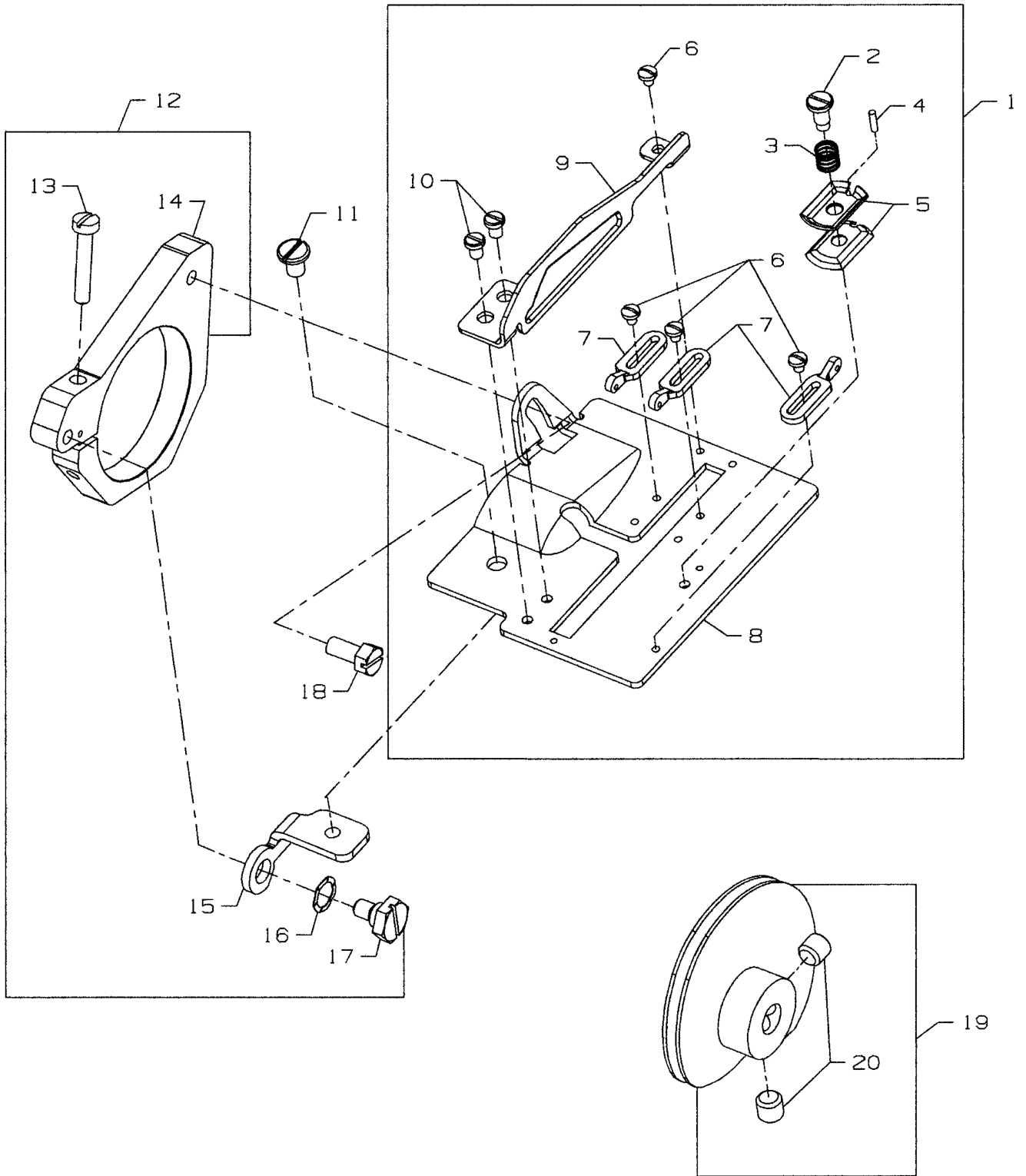

From the library of: Diamond Needle Corp



LOOPER THREAD TAKE-UP

Ref. No.	Part No.	Description	Amt. Req.
1.	50357AM	Cast-Off Plate Assembly	1
2.	SD0380551SL	Knurled Nut	1
3.	50332AC	Tension Spring	1
4.	50347R	Roll Pin	1
5.	51959B	Tension Disc	2
6.	SS7060310SP	Screw	4
7.	52958D	Take-up Eyelet	3
8.	50357AN	Cast-off Plate	1
9.	50304N	Retaining Finger	1
10.	SS6080410SP	Screw	2
11.	SS6110610TP	Screw, for cast-off holder	1
12.	29476UK	Cast-Off Plate Holder Assembly	1
13.	SS9111010SP	Screw, for collar bracket	1
14.	50383F	Take-up Collar Bracket	1
15.	50304K	Cast-Off Plate Holder	1
16.	50386J	Washer	1
17.	SD0630275SP	Shoulder Screw, for cast-off plate holder	1
18.	SS9111010SP	Screw, for collar bracket	1
19.	50323R	Take-up Assembly	1
20.	SS8660612TP	Set Screw	2

From the library of: Diamond Needle Corp



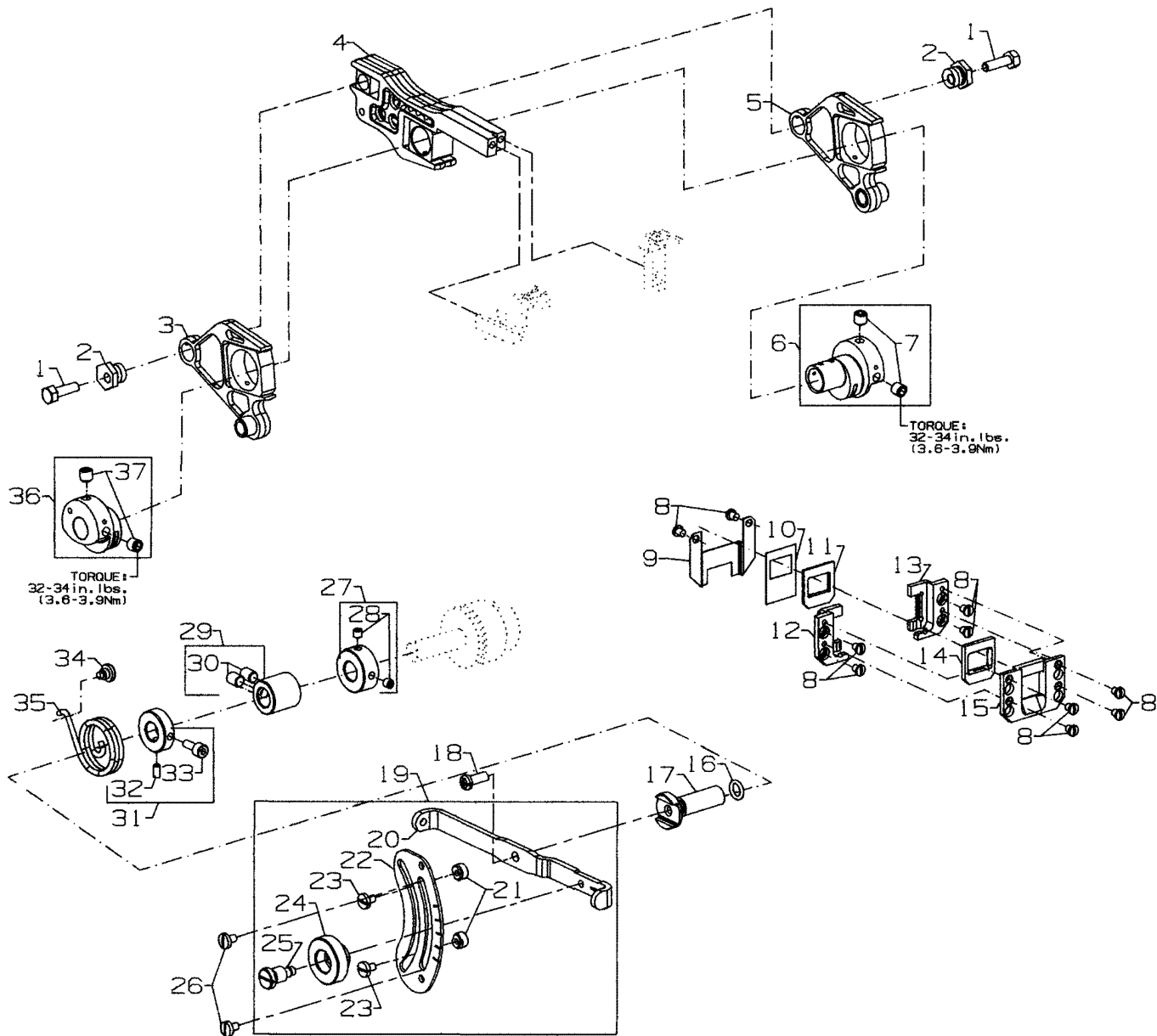

FEED DRIVE MECHANISM
FOR
FS322C01, FS332CO1, FS335E41, FS335E42
FS322H01, FS332H01, FS332L01, FS332L21

Ref. No.	Part No.	Description	Amt. Req.
1.	18-1432	Screw	2
2.	50334BD	Hex Eccentric Stud	2
3.	50334AW	Drive Fork Assembly	1
4.	50334BE	Feed Bar Assembly	1
5.	50334AX	Drive Fork Assembly, right	1
6.	50340D	Feed Eccentric, main	1
7.	SS8660612TP	Screw	2
8.	SS7090530SP	Screw	10
9.	50334Y	Oil Shield	1
10.	50334V	Oil Scraper	1
11.	50334BH	Feed Bar Seal	1
12.	50335AM	Guide Plate, left, rear	1
13.	50335BA	Guide Plate, right, rear	1
14.	50334BJ	Feed Bar Seal	1
15.	50335AN	Guide Plate, front	1
16.	RO0681190100	"O" Ring	1
17.	50337J	Stem, for differential feed lever	1
18.	SS4121215SP	Screw, for stem	1
19.	29476YH	Differential Feed Lever Assembly	1
20.	50337H	Differential Feed Lever	1
21.	50337U	Stop	2
22.	50337BD	Plate, for differential feed lever	1
23.	SS7090610SP	Screw	2
24.	B1647704000A	Knob, for differential feed lever	1
25.	50387	Screw	1
26.	SS7090610SP	Screw	2
27.	50337S	Collar	1
28.	SS8110422TP	Screw	2
29.	50337L	Coupling, for differential feed lever	1
30.	SS6110650TP	Screw	2
31.	50337R	Collar, for differential feed lever	1
32.	SS8090710SP	Screw	1
33.	SS6091022TP	Screw	1
34.	SP0550271TP	Screw, for spring	1
35.	50337M	Spring, for differential feed lever	1
36.	50340F	Feed Eccentric, differential	1
37.	SS8660612TP	Screw	2

From the library of: Diamond Needle Corp



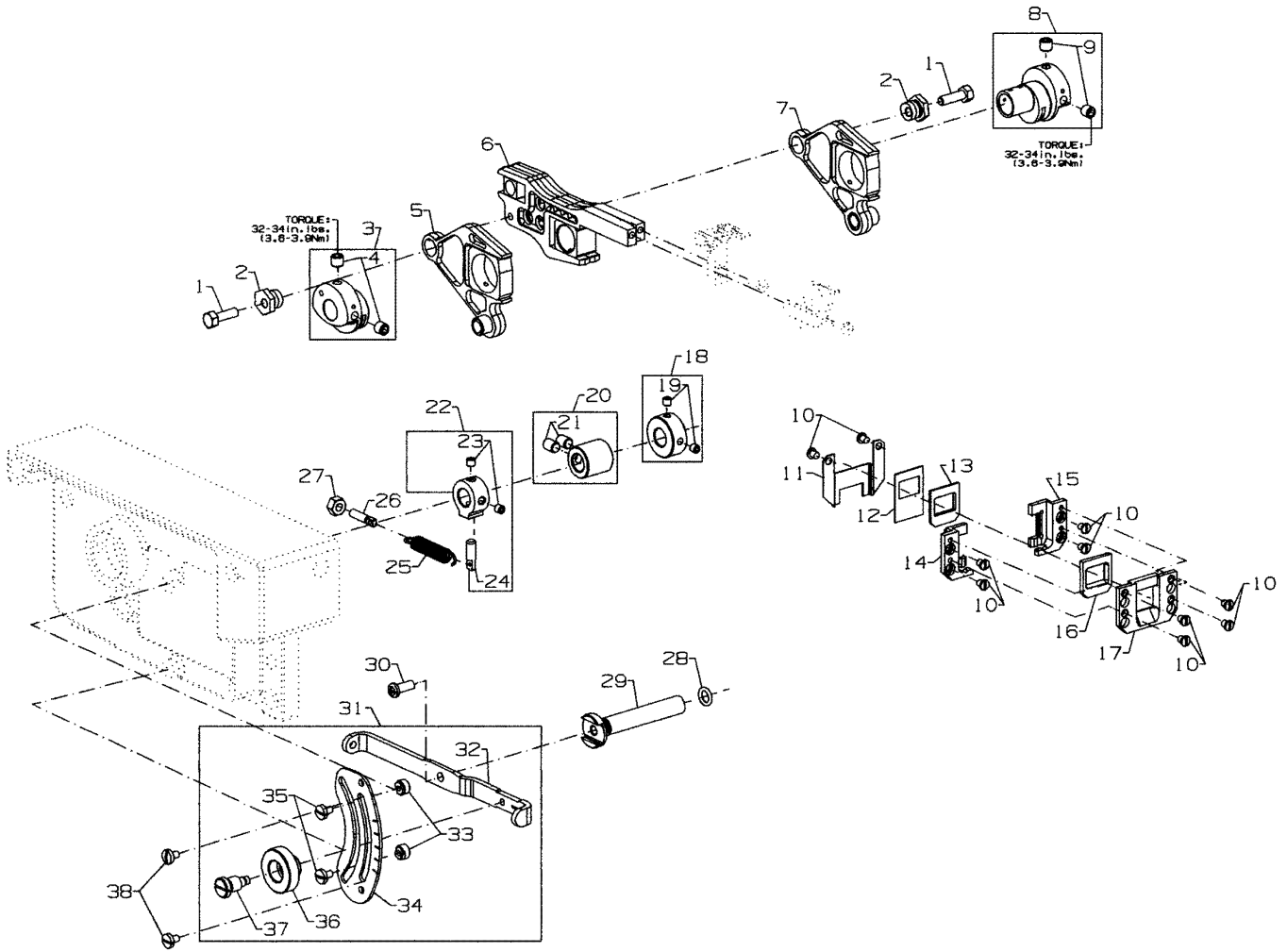

FEED DRIVE MECHANISM
FOR
FS322E12 & FS332E12

Ref. No.	Part No.	Description	Amt. Req.
1.	18-1432	Screw	2
2.	50334BD	Hex Eccentric Stud	2
3.	50340F	Feed Eccentric, differential	1
4.	SS8660612TP	Screw, for Feed Eccentric, differential.....	2
5.	50334AW	Drive Fork Assembly, left	1
6.	50334BE	Feed Bar Assembly	1
7.	50334AX	Drive Fork Assembly, right	1
8.	50340D	Feed Eccentric, main	1
9.	SS8660612TP	Screw	2
10.	SS7090530SP	Screw	10
11.	50334Y	Oil Shield	1
12.	50334V	Oil Scraper, front	1
13.	50334BH	Feed Bar Seal	1
14.	50335AM	Guide Plate, left, rear	1
15.	50335BA	Guide Plate, right, rear	1
16.	50334BJ	Feed Bar Seal	1
17.	50335AN	Guide Plate, front	1
18.	50337S	Collar	1
19.	SS8110422TP	Screw	2
20.	50337L	Coupling, for differential feed lever	1
21.	SS6110650TP	Screw	1
22.	50335AS	Collar, for differential feed lever	1
23.	SS8110422TP	Screw	2
24.	50336V	Pin, for differential feed lever	1
25.	50332W	Spring	1
26.	18-1445	Spring Latch Screw	1
27.	NS6110530SP	Nut	1
28.	RO068190100	"O" Ring	1
29.	50337Y	Stem, for differential feed lever	1
30.	SS4121215SP	Screw, for Stem	1
31.	29476YH	Differential Feed Lever Assembly	1
32.	50337H	Differential Feed Lever	1
33.	50337U	Stop	2
34.	50337BD	Plate, for differential feed lever	1
35.	SS7090610SP	Screw	2
36.	B1647704000A	Knob, for differential feed lever	1
37.	50387	Screw	1
38.	SS7090610SP	Screw	2

From the library of: Diamond Needle Corp



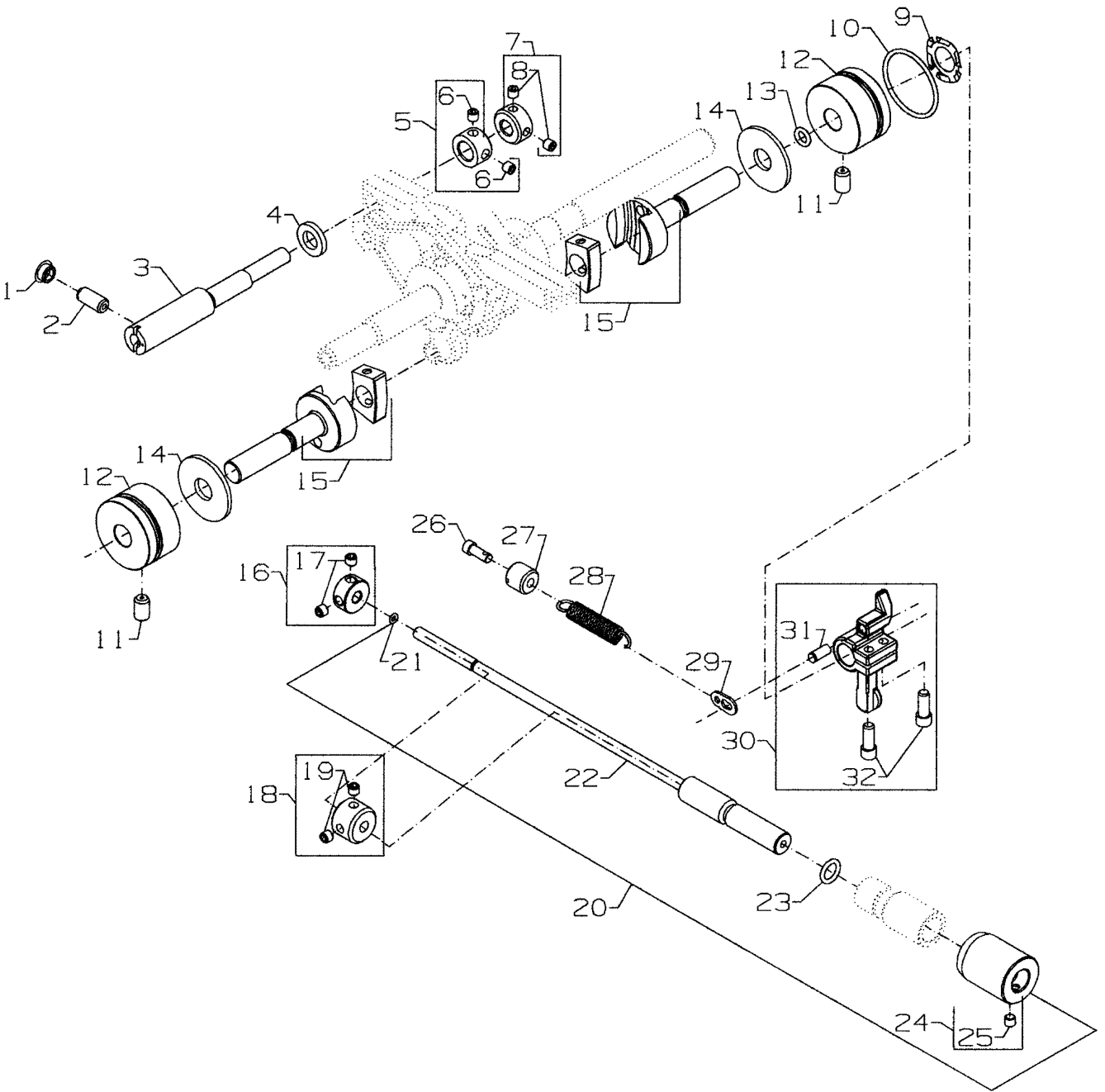

FEED DRIVE MECHANISM

Ref. No.	Part No.	Description	Amt. Req.
1.	TA0750404R0	Plug, for eccentric shaft	1
2.	22591A	Screw, for eccentric shaft	1
3.	50334BC	Eccentric Shaft	1
4.	50368AD	Washer, for eccentric shaft	1
5.	50334BB	Collar, for eccentric shaft	1
6.	SS8110422TP	Screw, for collar	2
7.	50337T	Collar, for eccentric shaft	1
8.	SS8110422TP	Screw, for collar	2
9.	661-96	Spring Washer	1
10.	660-695	"O" Ring, for bushing	1
11.	SS8661012TP	Screw, for bushing	1
12.	35036F	Bushing, for stitch adjusting shaft	1
13.	660-220	"O" Ring, for stitch adjusting shaft	1
14.	35036AZ	Brake Pad	1
15.	50634G	Stitch Adjusting Shaft Assembly	1
16.	50335D	Collar	1
17.	22894P	Screw	2
18.	50333T	Collar	1
19.	22894P	Screw	2
20.	29476UF	Stitch Length Adjusting Rod Assembly	1
21.	660-980	"O" Ring, stitch control shaft	1
22.	50322AR	Shaft, for stitch control	1
23.	660-206	"O" Ring, for stitch control shaft	1
24.	50336Y	Stitch Knob, indicator	1
25.	SS8110422TP	Screw	1
26.	50335	Spring Retainer	1
27.	22714C	Screw, for spring retainer	1
28.	50355	Spring	1
29.	50335A	Spring Holder	1
30.	50336S	Stitch Control Lever	1
31.	661-35	Pin	1
32.	22596H	Screw	2

From the library of: Diamond Needle Corp



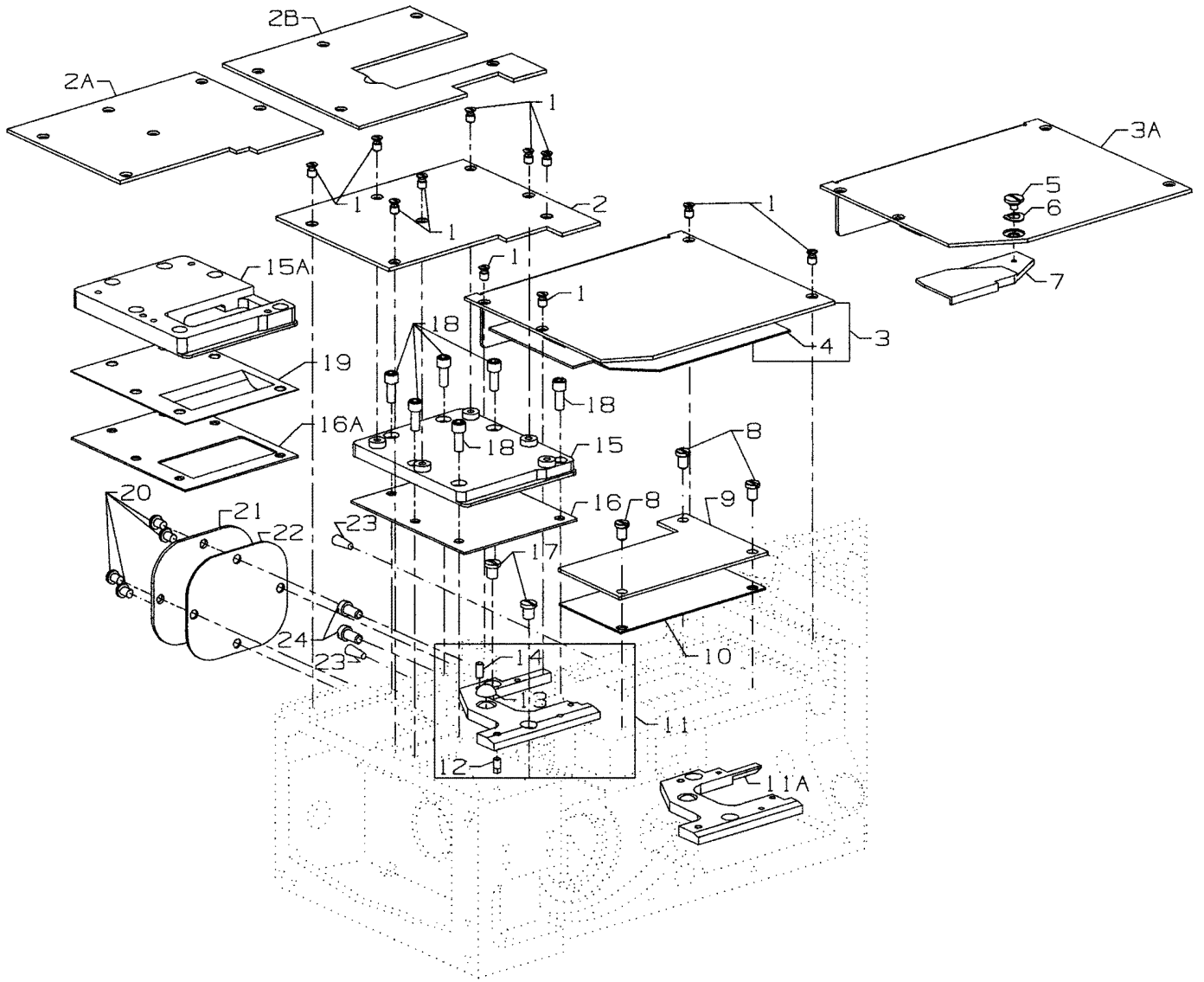

From the library of: Diamond Needle Corp



COVERS, LOWER BED

Ref. No.	Part No.	Description	Amt. Req.
1.	18-1448	Screw	9-11
2.	50301BH	Cloth Plate, left, for FS332L01, FS332L21, FS322H01, FS332H01	1
2A.	50301BA	Cloth Plate, left, for FS322C01, FS332C01, FS322E12, FS332E12	1
2B.	50301CH	Cloth Plate, left, for FS335E41, FS332E42	1
3.	50301BF	Cloth Plate, right, for FS322H01, FS332H01, FS332L01, FS332L21, FS335E41, FS335E42	1
3A.	50301AZ	Cloth Plate, right, for FS322C01, FS332C01, FS322E12, FS332E12	1
4.	50303B	Accoustic Pad	1
5.	22726	Screw for Swing Plate, for FS332C01, FS332C01, FS335E41, FS335E42	1
6.	95978	Spring Washer, for FS332C01, FS332C01, FS335E41, FS335E42.....	1
7.	50345U	Swing Plate, for FS332C01, FS332C01, FS335E41, FS335E42	1
8.	22839C	Screw, for FS322H01, FS332H01, FS332L01, FS332L21	3
9.	50382JR	Cover, for FS322H01, FS332H01, FS332L01, FS332L21	1
10.	50384K	Gasket, for FS322H01, FS332H01, FS332L01, FS332L21	1
11.	50380KA	Throat Plate Support Complete, for FS335E41, FS335E42, FS322H01, FS332H01, FS332L01, FS332L21,	1
11A.	50380LA	Throat Plate Support Complete, for FS322C01, FS332C01, FS322E12, FS332E12	1
12.	50328	Diamond Pin	1
13.	660-939	Rubber Bumper, for throat plate support	1
14.	50336W	Dowel Pin, for throat plate support	1
15.	50382CP	Cover for Feed Chamber, for FS322C01, FS332C01, FS322E12, FS332E12, FS322H01, FS332H01, FS322L01, FS332L21,	1
15A.	50382CT	Cover for Feed Chamber, for FS335E41, FS335E42	1
16.	50382CS	Gasket for FS322H01, FS332H01, FS332L01, FS332L21, FS322E12, FS332E12, FS322C01, FS332C01	1
16A.	50384E	Gasket, for FS335E41, FS335E42	1
17.	SS7150740SP	Screw	2
18.	SS6121212TP	Screw, for feed chamber cover	6
19.	37-70BLK	Cover Blank, for FS335E41, FS335E42	1
20.	SS4120615SP	Screw	4
21.	50382CL	Cover, rear, for feed chamber	1
22.	50382CR	Gasket	1
-	CE63	Three Bond Adhesive (not shown), for screw	-
23.	CO67D	Cork	2
24.	22517	Screw, for bed	2

From the library of: Diamond Needle Corp



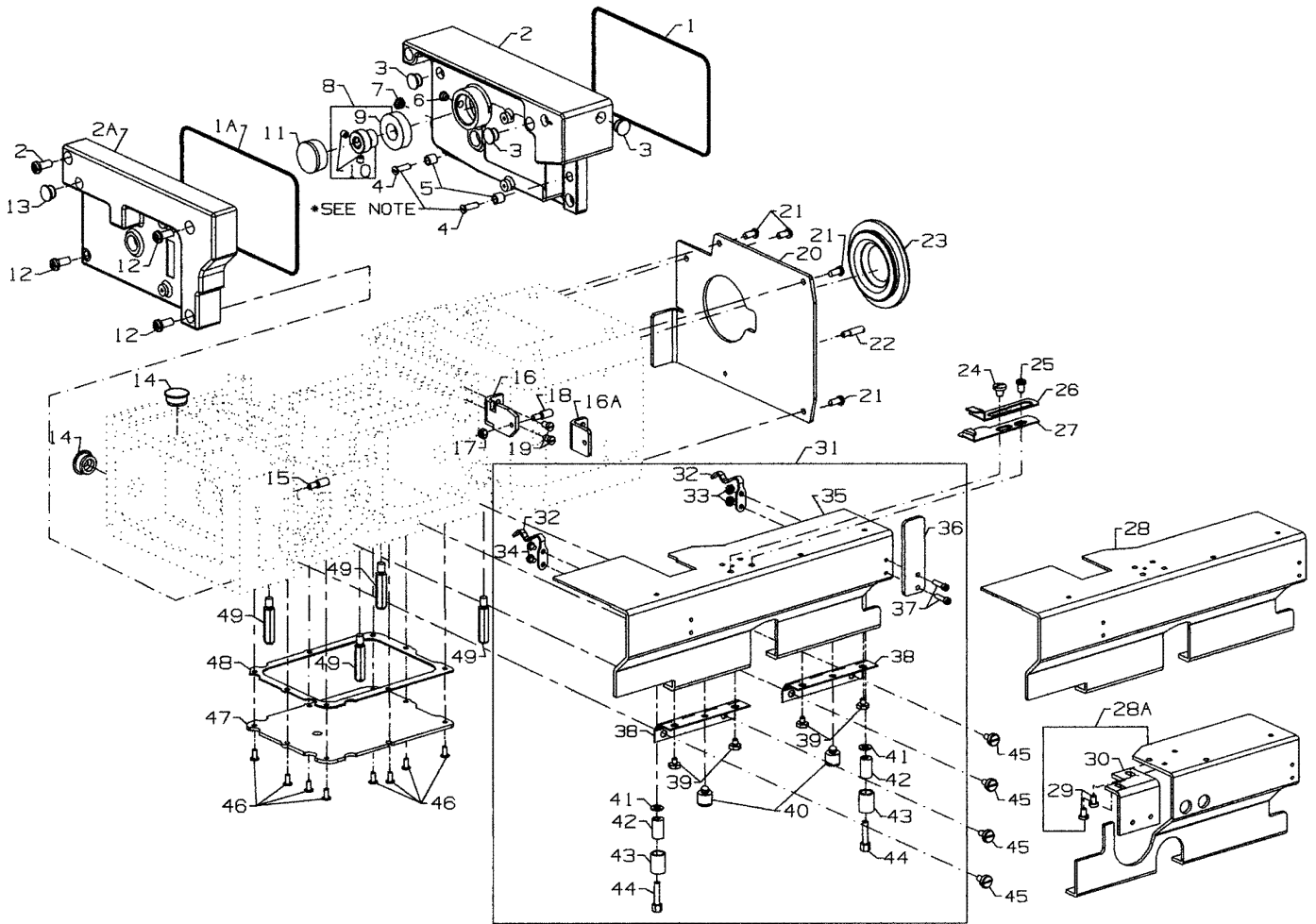

*THESE SCREWS SHOULD NOT BE LOOSENED WHEN TAKING APART.



COVERS, LOWER BED

Ref. No.	Part No.	Description	Amt. Req.
1.	50382GK	Quad Ring for end cover, for FS322E12, FS332E12	1
1A.	50382CM	Quad Ring for end cover, for FS335E41, FS335E42, FS322H01, FS332H01, FS332L01, FS332L21	1
2.	50382KF	Left End Cover, for FS322E12, FS332E12	1
2A.	50382KE	Left End Cover, for FS335E41, FS335E42, FS322H01, FS332H01, FS332L01, FS332L21,	1
3.	TA1100604R0	Plug, for FS322C01, FS332C01, FS322E12, FS332E12,	1/3
4.	22541A	Screw, for FS322E12, FS332E12	2
5.	50336L	Ferrule, for FS322E12, FS332E12	2
6.	TA0620504R0	Plug for Left End Cover, for FS322E12, FS332E12	1
7.	TA0750404R0	Plug, for FS322E12, FS332E12	2
8.	50336	Bearing Thrust Collar, for FS322E12, FS332E12	1
9.	660-974	Bearing, FS322E12, FS332E12	1
10.	22894C	Screw	2
11.	999-216C	Plug, for FS322E12, FS332E12	1
12.	SS4151415SP	Screw	4
13.	TA1100604R0	Plug, for FS335E41, FS335E42, FS322H01, FS332H01, FS332L01, FS332L21.	1
14.	50393HB	Plug	1
15.	22799AH	Spring Latch Stud, for FS322C01, FS332C01, FS335E41, FS335E42, FS322H01, FS332H01, FS322L01, FS332L21,	2
16.	50332B	Support Block, for FS332L21, FS322E12, FS332E12, FS335E41, FS335E42, FS322H01, FS332H01, FS332L01, FS332L21	1
16A.	50357AC	Support Block, for FS322C01, FS332C01.....	1
17.	35569J	Nut	1
18.	22799AH	Spring Latch Stud	1
19.	SS7120710SP	Screw	2
20.	50382CJ	Cover, for drive belt	1
21.	SS4121015SP	Screw	4
22.	22799M	Stop Stud (used only with synchronizer).....	1
23.	50393HU	Plug for right end non-synchronizer	1
24.	25S	Screw, for FS322H01, FS332H01.....	1
25.	22839C	Screw, for FS322H01, FS332H01.....	1
26.	34703F2	Holder, upper, for FS322H01, FS332H01.....	1
27.	34703E1	Hemmer, lower, for FS322H01, FS332H01	1
28.	50382JB	Swing Down Cover, for FS335E41, FS335E42	1
28A.	50382FS	Front Cover Assembly, for FS322E12, FS332E12	1
29.	94	Screw	2
30.	50332F	Bracket	1
31.	29476VX	Front Cover Assembly, for FS322H01, FS332H01, FS332L01, FS332L21.....	1
32.	50332A	Latch Spring	1/2
33.	41071G	Nut	2
34.	22513D	Screw	2
35.	50382CK	Swing Down Cover	1
36.	50363CH	Lever	1
37.	22729D	Screw	2
38.	50378S	Hinge	2
39.	SS9110543CP	Screw	4
40.	660-1020	Rubber Bumper	2
41.	20	Washer	2
42.	50382T	Stop, for front cover	2
43.	50393W	Rubber Bumper	2
44.	22519J	Screw	2
45.	SS6120930TP	Screw	4
46.	SS7090850SP	Screw	8
47.	50382CG	Dry Chamber Cover	1
48.	50383G	Gasket, for chamber cover	1
49.	22841U	Machine Support Stud	4

From the library of: Diamond Needle Corp



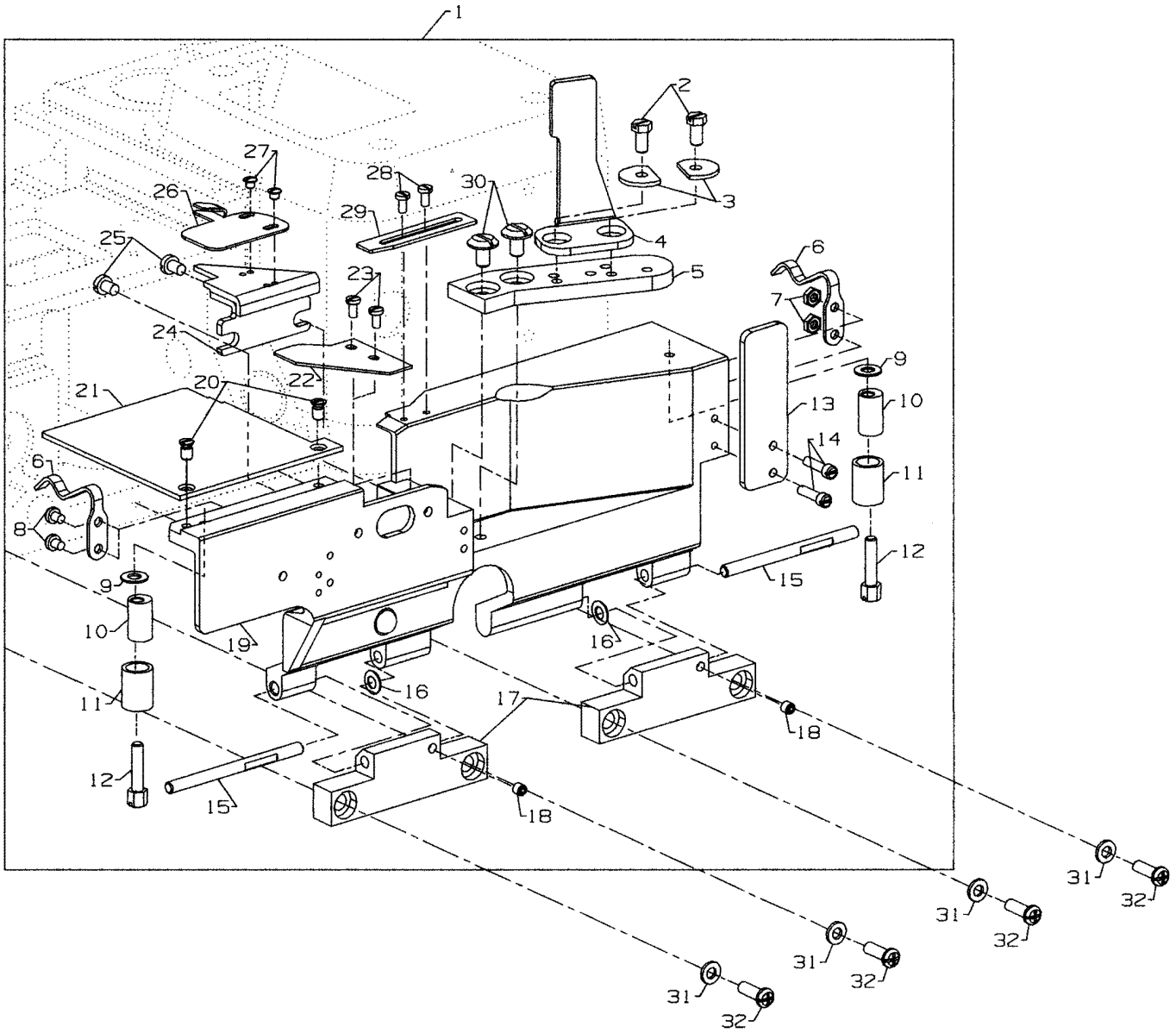

From the library of: Diamond Needle Corp



FRONT COVER ASSEMBLY
FOR
FS322C01, FS332C01

Ref. No.	Part No.	Description	Amt. Req.
1.	29476VY	Front Cover Assembly	1
2.	22882E	Hex Head Screw	2
3.	50368H	Washer	2
4.	52864W	Folder Support Bracket	1
5.	50364M	Mounting Bracket	1
6.	50332A	Latch Spring	2
7.	41071G	Nut	2
8.	22513D	Screw	2
9.	20	Washer	2
10.	50382T	Front Cover Stop	2
11.	50393W	Rubber Bumper	2
12.	22519J	Screw	2
13.	50363CH	Lever, front cover	1
14.	22729D	Screw	2
15.	50347P	Hinge Pin	2
16.	97127	Spring Washer	2
17.	50378T	Hinge	2
18.	22894W	Set Screw	1
19.	50382FT	Swing Down Cover	1
20.	22525A	Screw	2
21.	50301AY	Cloth Plate	1
22.	50382BB	Looper Shield	1
23.	77L	Screw	2
24.	50364P	Platform	1
25.	94	Screw	2
26.	50303C	Edge Guide	1
27.	77F	Screw	2
28.	77L	Screw	2
29.	50343A	Plate, for folder	1
30.	22517B	Screw	2
31.	8372A	Washer	4
32.	SS4121415SP	Screw	4

From the library of: Diamond Needle Corp



TORQUE:
14-16 in. lbs.
(1.6-1.8 Nm)

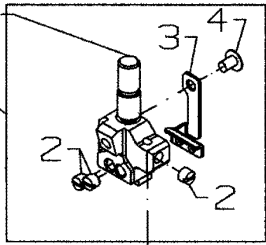

TORQUE:
14-16 in. lbs.
(1.6-1.8 Nm)

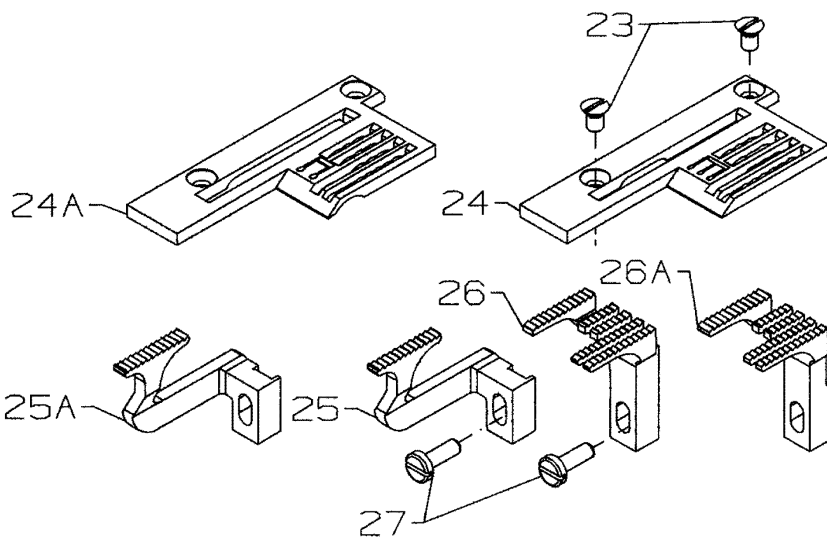
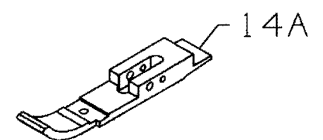
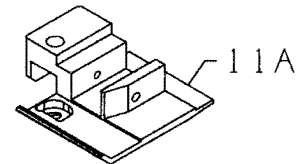
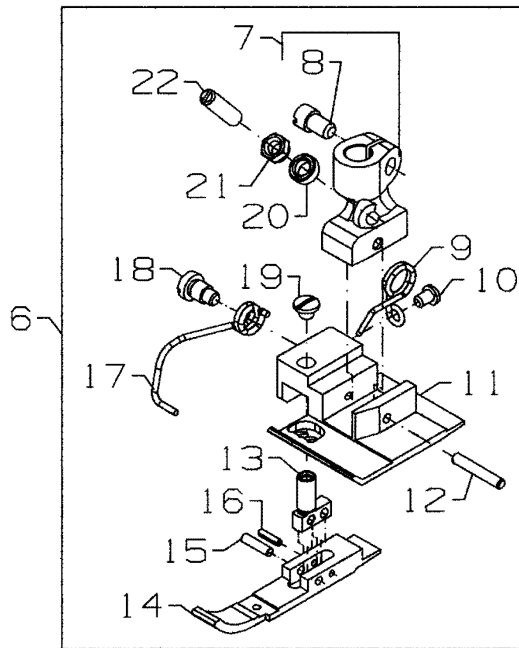
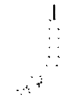
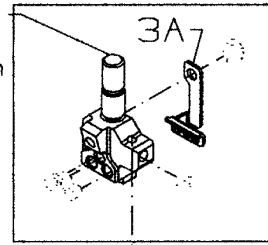

From the library of: Diamond Needle Corp



**SEWING PARTS
FOR
FS322C01 & FS332C01**

Ref. No.	Part No.	Description	Amt. Req.
1.	-----	Needle Head, for 2 needle sewing comb., (see chart)	1
1A.	-----	Needle Head, for 3 needle sewing comb., (see chart)	1
2.	SS8080310TP	Screw, for Needle Head	3/4
3.	50318AE40	Eyelet, per Needle Head, for 2 needle sewing comb.	1
3A.	50318AE56	Eyelet, per Needle Head, for 3 needle sewing comb.	1
4.	SS6060440TP	Screw, for Eyelet	1
5.	50392G	Needle Thread Eyelet	1
6.	-----	Presser Foot Assembly, for sewing comb., (see chart)	1
7.	34730H	Presser Foot Shank	1
8.	91	Screw	1
9.	97109	Torsion Spring	1
10.	605	Screw	1
11.	50330BN48	Presser Foot Bottom, for 50320V48	1
-	50330BN16	Presser Foot Bottom, for 50320V16	1
11A.	50330BN12	Presser Foot Bottom, for 50320U12	1
-	50330BN8	Presser Foot Bottom, for 50320U8	1
12.	22799B	Screw, for hinge	1
13.	G65-181	Plunger	1
14.	50330BP16	Presser Foot Yielding Section	1
15.	96532	Roll Pin	1
16.	96671	Roll Pin	1
17.	52830G	Spring	1
18.	57WD	Screw, for spring	1
19.	187A	Screw, for plunger	1
20.	51959E	Collar	1
21.	51430F	Nut	1
22.	22565E	Screw	1
23.	87	Screw, for throat plate	2
24.	-----	Throat Plate, for 3 needle sewing comb., (see chart)	1
24A.	-----	Throat Plate, for 2 needle sewing comb., (see chart)	1
25.	-----	Differential Feed Dog, for sewing comb., (see chart)	1
26.	-----	Main Feed Dog, for sewing comb., (see chart)	1
27.	SS7091110TP	Screw, for feed dogs	2

From the library of: Diamond Needle Corp

MODEL	NEEDLE HEAD	PRESSER FOOT ASSEMBLY	THROAT PLATE	FEED DOG MAIN	FEED DOG DIFFERENTIAL
FS322C01-2D32	50318AM32	50320U8	34724XX8	50305AZ	50326AZ
FS322C01-2D40	50318AM40	50320U12	34724XX10		
FS322C01-2D48	50318AM48	50320V48	50324XX48	50305AU	50326AG
FS322C01-3D48			34724XX48		
FS322C01-3D56	50318AM56	50320V16	34724XX56		
FS322C01-3D64	50318AM64		34724XX64		
FS332C01-2D32	50318AM32	50320U8	34724XX8	50305AZ	50326AZ
FS332C01-2D40	50318AM40	50320U12	34724XX10		
FS332C01-2D48	50318AM48	50320V48	50324XX48	50305AU	50326AG
FS332C01-3D48			34724XX48		
FS332C01-3D56	50318AM56	50320V16	34724XX56		
FS332C01-3D64	50318AM64		34724XX64		



MODEL	NEEDLE HEAD	PRESSER FOOT ASSEMBLY	THROAT PLATE	FEED DOG MAIN	FEED DOG DIFFERENTIAL
FS322E12-2D32	50318AM32	50320W8	34824TD8	50305AZ	50326BA
FS322E12-2D40	50318AM40	50320W12	34824TD10		50326BB
FS322E12-2D48	50318AM48	50320X48	34824TD48	50305AU	50326AF
FS322E12-3D48					
FS322E12-3D56	50318AM56	50320X16	34824TD56		
FS322E12-3D64	50318AM64		34824TD64		

From the library of: Diamond Needle Corp



MODEL	NEEDLE HEAD	PRESSER FOOT ASSEMBLY	THROAT PLATE	FEED DOG MAIN	FEED DOG DIFFERENTIAL
FS332E12-2D32	50318AM32	50320W8	34824TD8	50305AZ	50326BA
FS332E12-2D40	50318AM40	50320W12	34824TD10		50326BB
FS332E12-2D48	50318AM48	50320X48	34824TD48	50305AU	50326AF
FS332E12-3D48					
FS332E12-3D56	50318AM56	50320X16	34824TD56		
FS332E12-3D64	50318AM64		34824TD64		

From the library of: Diamond Needle Corp



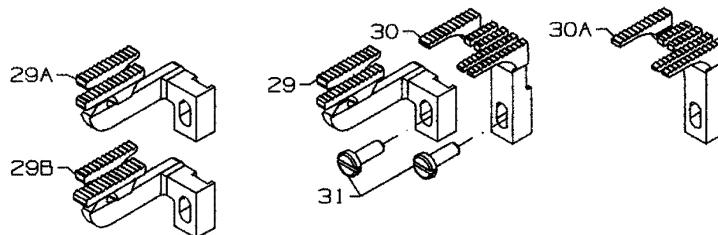
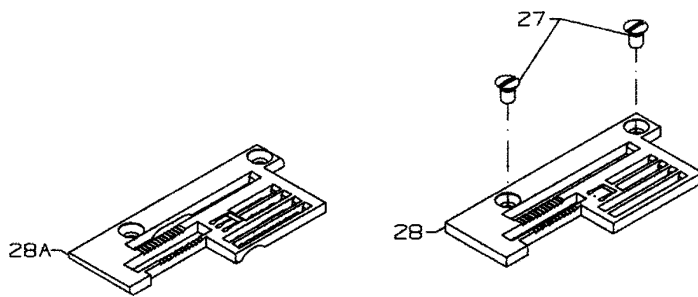
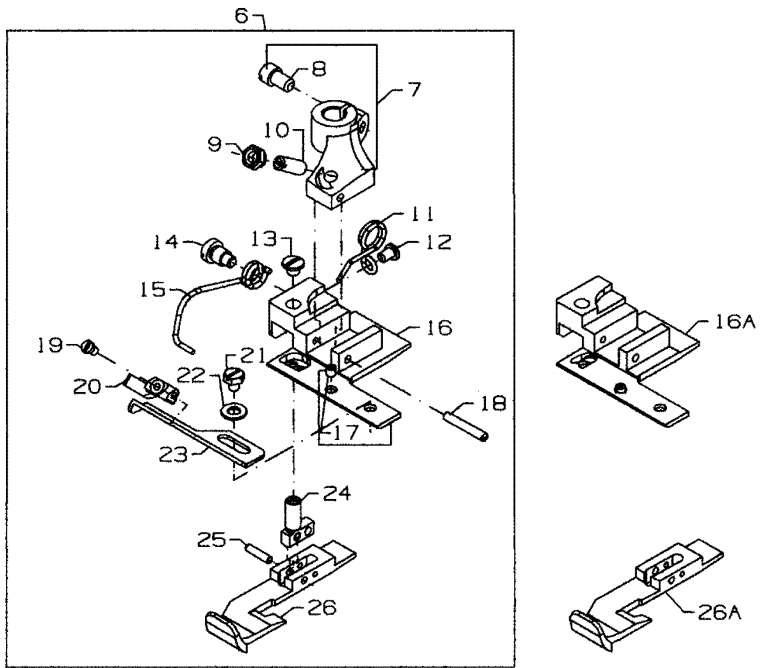
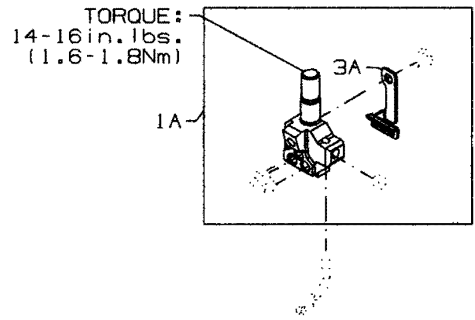
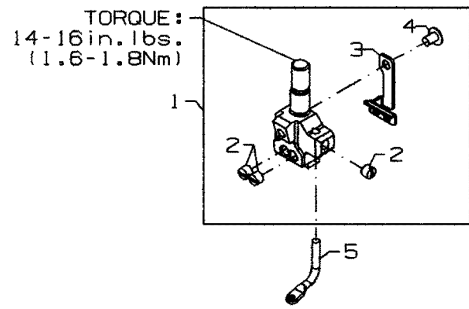

SEWING PARTS
FOR
FS322E12 & FS332E12

Ref. No.	Part No.	Description	Amt. Req.
1.	-----	Needle Head, for sewing comb., (see chart)	1
2.	SS5060410SP	Screw	4-6
3.	50318AE40	Eyelet, per needle head, for FE12-2D32, FE12-2D40	1
3a.	50318AE56	Eyelet, per needle head, for FE12-2D48, FE12-3D48, FE12-3D56, FE12-3D64	1
4.	SS6060440TP	Screw, for eyelet	1
5.	50392G	Needle Thread Eyelet	1
6.	-----	Presser Foot Assembly, for sewing comb., (see chart)	1
7.	52730T	Presser Foot Shank	1
8.	91	Screw	1
9.	51430F	Nut	1
10.	22840A	Screw	1
11.	97109	Spring	1
12.	605	Screw	1
13.	187A	Screw	1
14.	57WD	Screw	1
15.	52830G	Spring	1
16.	50330CE16	Presser Foot Bottom, per presser foot, for FE12-3D56, FE12-3D64	1
-	50330CE48	Presser Foot Bottom, per presser foot for, FE12-2D48, FE12-3D48	1
16A.	50330CC8	Presser Foot Bottom, per presser foot for, FE12-2D32	1
-	50330CC12	Presser Foot Bottom, per presser foot for, FE12-2D40	1
17.	73B	Screw	1
18.	22799B	Screw	1
19.	22738B	Screw	1
20.	34830MA	Tape Margin	1
21.	99373A	Screw	1
22.	95956	Washer	1
23.	34830LA	Tape Guide	1
24.	G65-181	Plunger	1
25.	96532	Roll Pin	1
26.	50330CF	Yielding Section, for sewing comb., FE12-2D48, FE12-3D48, FE12-3D56, FE12-3D60, FE12-3D64	1
26A.	50330CD	Yielding Section, for sewing comb., FE12-2D32, FE12-2D40	1
27.	87	Screw, for throat plate	2
28.	-----	Throat Plate, for sewing comb., (see chart).....	1
28A.	-----	Throat Plate, for sewing comb., (see chart)	1
29.	-----	Differential Feed Dog, for sewing comb., (see chart).....	1
29A.	-----	Differential Feed Dog, for sewing comb., (see chart).....	1
29B.	-----	Differential Feed Dog, for sewing comb., (see chart)	1
30.	-----	Main Feed Dog, for sewing comb., (see chart)	1
30A.	-----	Main Feed Dog, for sewing comb., (see chart)	1
31.	SS7091110TP	Screw, for feed dogs	2

From the library of: Diamond Needle Corp



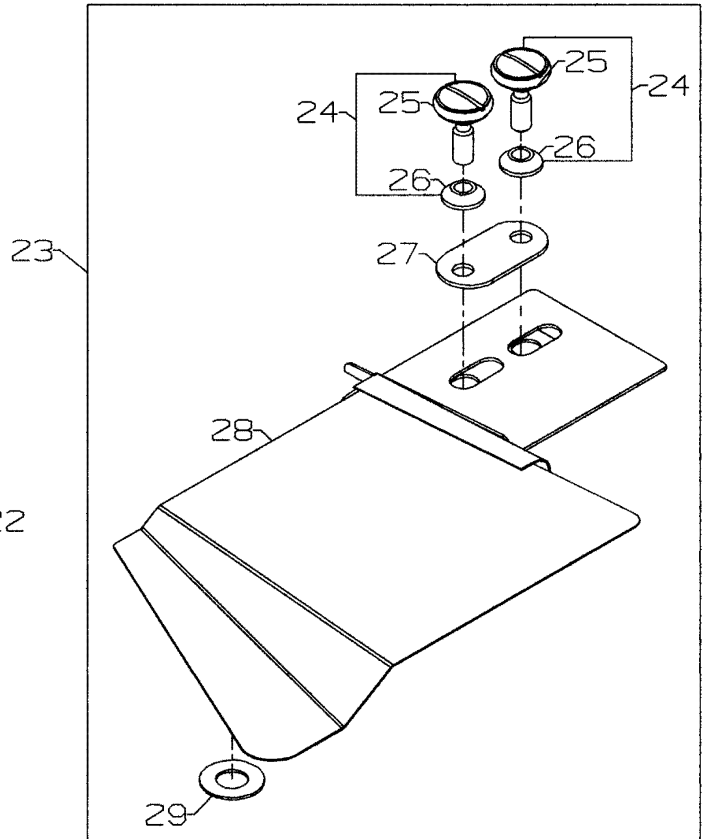
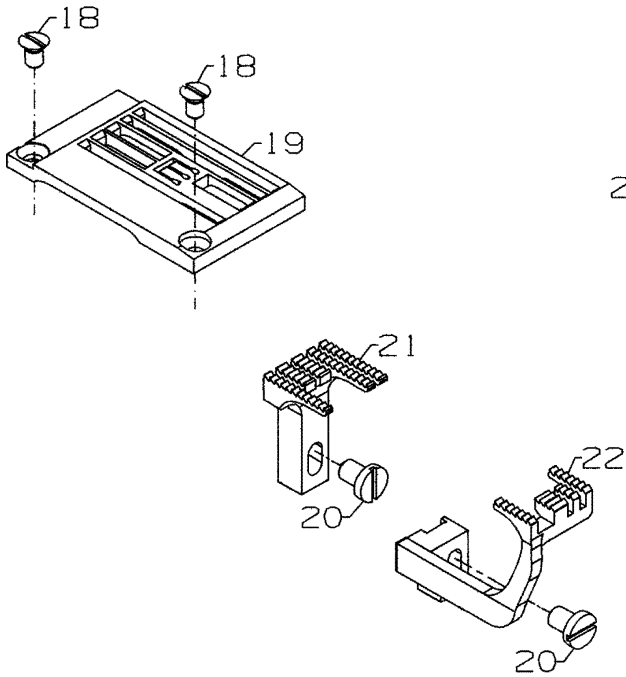
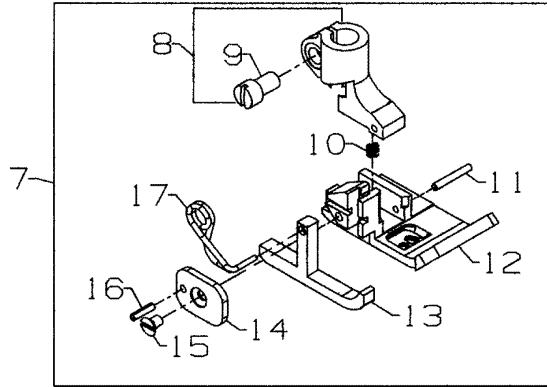
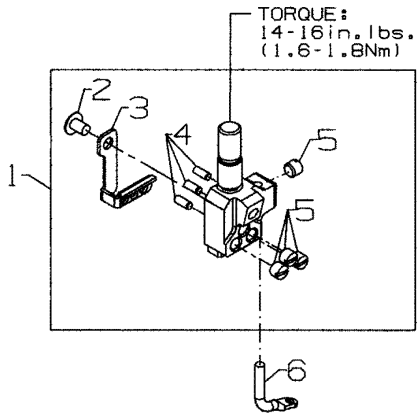

SEWING PARTS
FOR
FS335E41 & FS335E42

Ref. No.	Part No.	Description	Amt. Req.
1.	50318AA56	Needle Head, for sewing comb., (see chart)	1
-	50318AA64	Needle Head, for sewing comb., (see chart)	1
2.	SS5060410SP	Round Head Screw	1
3.	50318AE56	Eyelet, needle head, for sewing comb. (see chart)	1
4.	660-1046	Pin	3
5.	SS8080310TP	Screw	4
6.	50392G	Eyelet	1
7.	50320BF64	Presser Foot Assembly	1
8.	G57730GB	Shank	1
9.	91	Screw	1
10.	G57730GD	Torsion Spring	1
11.	6-25-55	Pin (01.5 x 10.5)	1
12.	50330BH64	Presser Foot Bottom	1
13.	34730A	Yielding Section	1
14.	G57730GC	Plate	1
15.	22716	Screw	1
16.	96651	Roll Pin	1
17.	39568J	Pressure Spring	1
18.	87	Screw, for throat plate	2
19.	50324DB56	Throat Plate, for sewing comb., (see chart)	1
-	50324DC64	Throat Plate, for sewing comb., (see chart)	1
20.	SS7091110TP	Screw, for feed dogs	2
21.	50305BS	Main Feed Dog	1
22.	50326BL	Differential Feed Dog	1
23.	29480AWR	Folder Kit	1
24.	25	Gauge Screw Assembly	2
25.	201C	Gauge Screw	2
26.	25D	Washer	2
27.	57864B	Washer Plate	1
28.	50389B	Folder	1
-	21210	Looper Collar (not shown)	1
29.	51493AF	Isolator	1

From the library of: Diamond Needle Corp

MODEL	NEEDLE HEAD	PRESSER FOOT ASSEMBLY	THROAT PLATE	FEED DOG MAIN	FEED DOG DIFFERENTIAL
FS332E12-2D32	50318AM32	50320W8	34824TD8	50305AZ	50326BA
FS332E12-2D40	50318AM40	50320W12	34824TD10		50326BB
FS332E12-2D48	50318AM48	50320X48	34824TD48	50305AU	50326AF
FS332E12-3D48					
FS332E12-3D56	50318AM56	50320X16	34824TD56		
FS332E12-3D64	50318AM64		34824TD64		



MODEL	NEEDLE HEAD	PRESSER FOOT ASSEMBLY	THROAT PLATE	FEED DOG MAIN	FEED DOG DIFFERENTIAL	
FS322H01-2A32	50318AM32	50320AH	50324BL32	50305BM	50326AY	
FS322H01-2C32			34724F8			
FS322H01-2A40	50318AM40		50324BL40			
FS322H01-2C40			34724F10			
FS322H01-2A48	50318AM48		50320T48			50324BL48
FS322H01-2C48						34724F48
FS322H01-3A48		50324BL48				
FS322H01-3B48		50324BS48				
FS322H01-3C48		34724F48				
FS322H01-3A56		50318AM56				50320T60
FS322H01-3B56	50324BS56					
FS322H01-3C56	34724F56					
FS322H01-3A64	50318AM64	50324BL64				
FS322H01-3B64		50324BS64				
FS322H01-3C64		34724F64				
FS332H01-2A32	50318AM32	50320AH	50324BL32			
FS332H01-2C32			34724F8			
FS332H01-2A40	50318AM40		50324BL40			
FS332H01-2C40			34724F10			
FS332H01-2A48	50318AM48		50320T48			50324BL48
FS332H01-2C48						34724F48
FS332H01-3A48		50324BL48				
FS332H01-3B48		50324BS48				
FS332H01-3C48		34724F48				
FS332H01-3A56		50318AM56		50320T60	50324BL56	
FS332H01-3B56	50324BS56					
FS332H01-3C56	34724F56					
FS332H01-3A64	50318AM64	50324BL64				
FS332H01-3B64		50324BS64				
FS332H01-3C64		34724F64				

From the library of: Diamond Needle Corp



MODEL	NEEDLE HEAD	PRESSER FOOT ASSEMBLY	THROAT PLATE	FEED DOG MAIN	FEED DOG DIFFERENTIAL		
FS332L01-2A32	50318AM32	50320AH	50324BN32	50305AN	50326AE		
FS332L01-2C32			50324BM32				
FS332L01-2A40	50318AM40		50324BK40				
FS332L01-2C40			50324BJ40				
FS332L01-3A48	50318AM48	50320T48	50324BN48				
FS332L01-3B48			50324BR48				
FS332L01-3C48			50324BM48				
FS332L01-3A56	50318AM56	50320T60	50324BN56			50305AV	50326AX
FS332L01-3B56			50324BR56				
FS332L01-3C56			50324BM56				
FS332L01-3A64	50318AM64		50324BN64				
FS332L01-3B64			50324BR64				
FS332L01-3C64			50324BM64				
FS332L21-3A56	50318AM56		50324BN56				
FS332L21-3B56			50324BR56				
FS332L21-3C56			50324BM56				
FS332L21-3A64	50318AM64		50324BN64				
FS332L21-3B64			50324BR64				
FS332L21-3C64			50324BM64				

From the library of: Diamond Needle Corp



TORQUE:
14-16 in. lbs.
(1.6-1.8 Nm)

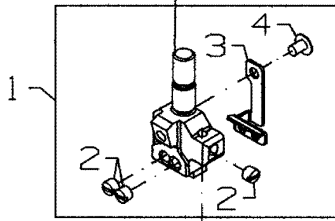

TORQUE:
14-16 in. lbs.
(1.6-1.8 Nm)

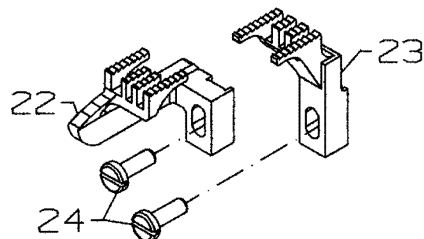
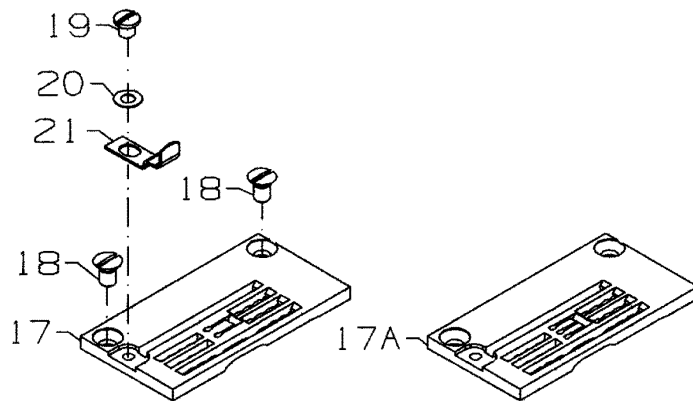
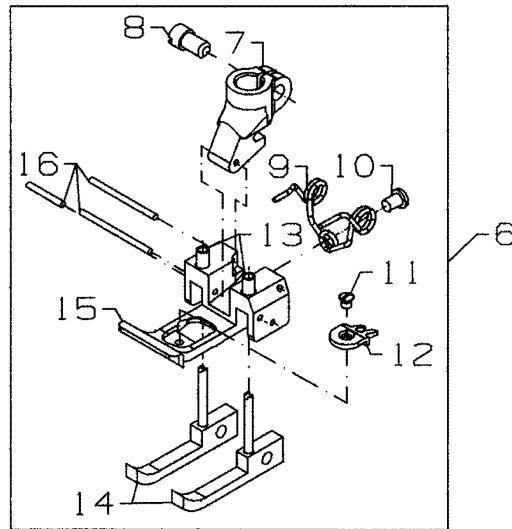
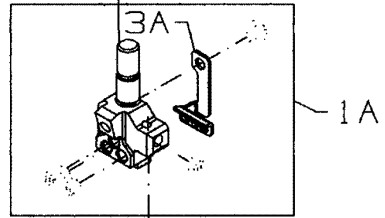

SEWING PARTS
FOR
FS322H01, FS332H01, FS332L01, FS332L21

Ref. No.	Part No.	Description	Amt. Req.
1.	-----	Needle Head, for two needle machines (see chart)	1
1A.	-----	Needle Head, for three needle machines (see chart)	1
2.	SS8080310TP	Screw	3/4
3.	50318AE40	Eyelet, per needle head, for sewing comb.,	1
3A.	50318AE56	Eyelet, per needle head, for sewing comb.,	1
4.	S5060410TP	Screw	1
5.	50392G	Needle Thread Eyelet	1
6.	-----	Presser Foot, for sewing comb., (see chart)	1
7.	G65-134	Presser Foot Shank	1
8.	91	Screw	1
9.	79633	Spring	1
10.	605	Screw	1
11.	22716A	Screw	1
12.	50397A16	Stitch Tongue, per presser foot, for gauges 5.6, 6.4	1
-	50397A48	Stitch Tongue, per presser foot, for gauge 4.8	1
12A.	50397C	Stitch Tongue, per presser foot, for gauges 3.2, 4.0	1
13.	G50-266	Bushing	2
14.	57830A	Yielding Section	1
15.	50330BL16	Presser Foot Bottom	2
16.	6-25-55	Drill Rod	3
17.	-----	Throat Plate, for sewing comb., (see chart)	1
17A.	-----	Throat Plate, for sewing comb., (see chart)	1
18.	87	Screw, for throat plate	2
19.	22561	Screw, for guide	1
20.	27-435BLK	Washer, for screw	2
21.	23195	Guide	1
22.	-----	Differential Feed Dog, for sewing comb., (see chart)	1
23.	-----	Main Feed Dog, for sewing comb., (see chart)	1
24.	SS7091110TP	Screw, for feed dogs	2

From the library of: Diamond Needle Corp



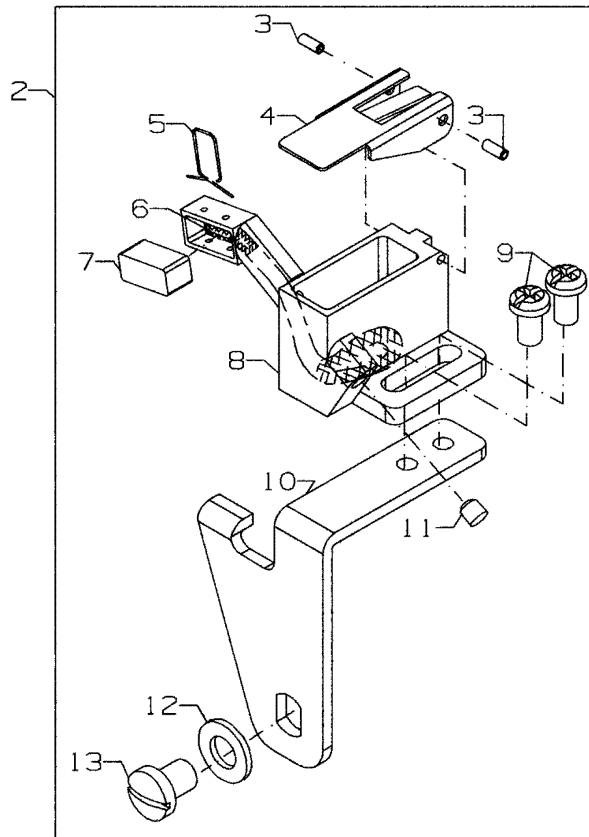
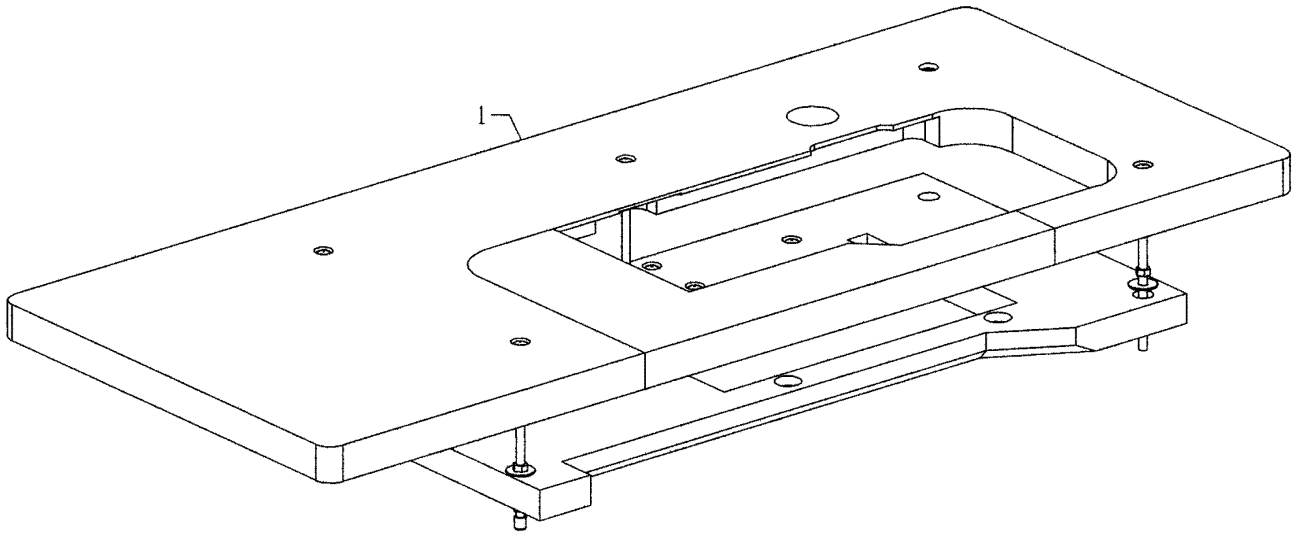

TABLING AND NEEDLE DIPPER ASSEMBLY
(EXTRA SEND CHARGE)

FOR

FS322C01, FS332CO1, FS335E41, FS335E42
FS322H01, FS332H01, FS332L01, FS332L21

Ref. No.	Part No.	Description	Amt. Req.
1.	21371AAE48	Table Board	1
2.	29476RZ	Needle Dipper Assembly	1
3.	PS0160042KH	Roll Pin	2
4.	50393JD	Needle Dipper Cover	1
5.	50393GS	Wire, for needle dipper	1
6.	CQ202000000	Oil Wick, for needle dipper	1
7.	50393GK	Felt, for needle dipper	1
8.	50393JC	Needle Dipper	1
9.	SS4090615SP	Screw, for needle dipper	2
10.	50393GP	Silicone Oil Tank Holder	1
11.	50393GG	Plug	1
12.	WP0531000SD	Washer	1
13.	SS4120615SP	Screw, for needle dipper holder.....	1

From the library of: Diamond Needle Corp



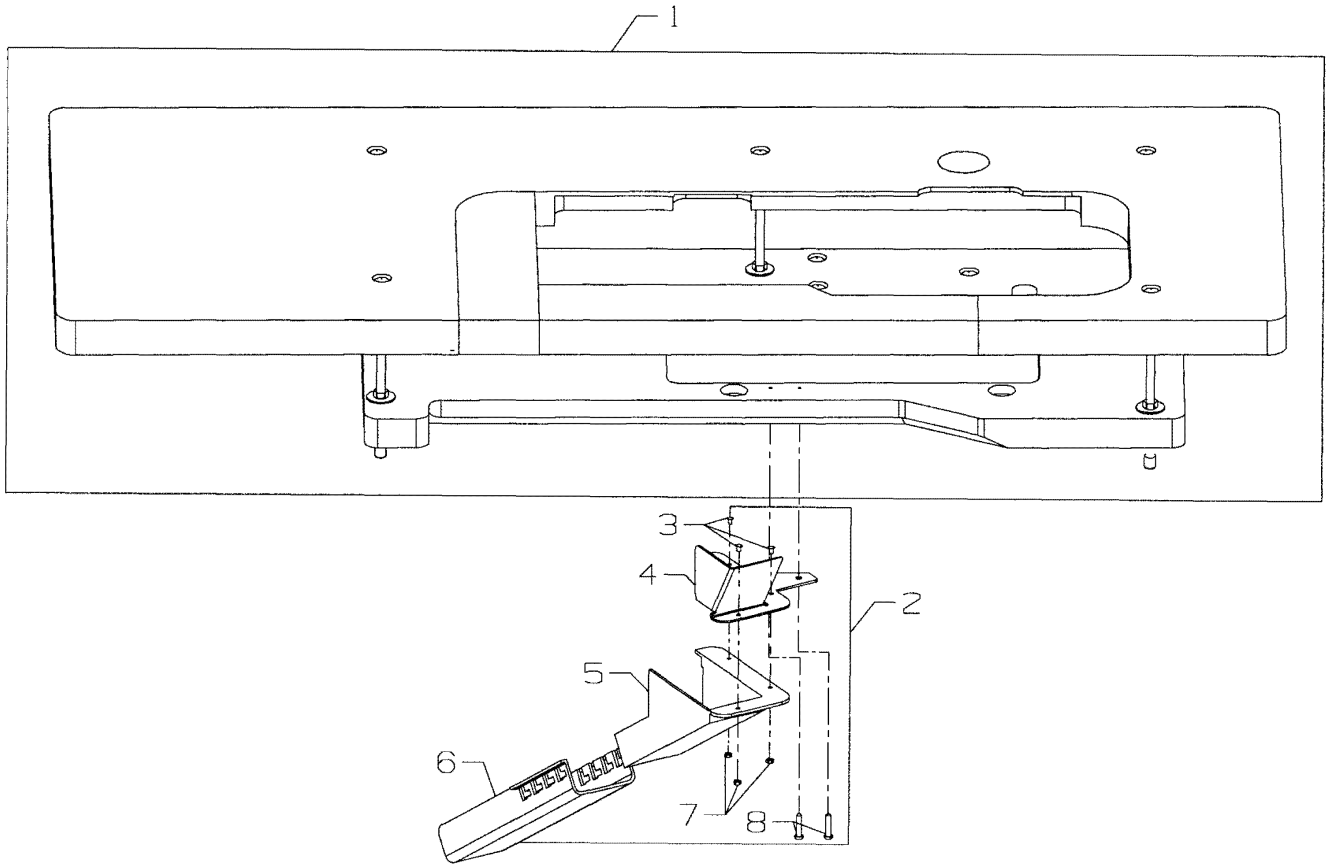

From the library of: Diamond Needle Corp



TABLING (EXTRA SEND CHARGE)
FOR
FS322E12 & FS332E12

Ref. No.	Part No.	Description	Amt. Req.
1.	21371AAG48	Table Board	1
2.	29480WR1	Waste Removal Kit	1
3.	SS5091020SP	Screw	3
4.	50383AC	Bracket	1
5.	11960101	Waste Chute	1
6.	11960002	Chute Extension	1
7.	NS6090310SP	Nut	3
8.	90561K	Wood Screw	2

From the library of: Diamond Needle Corp



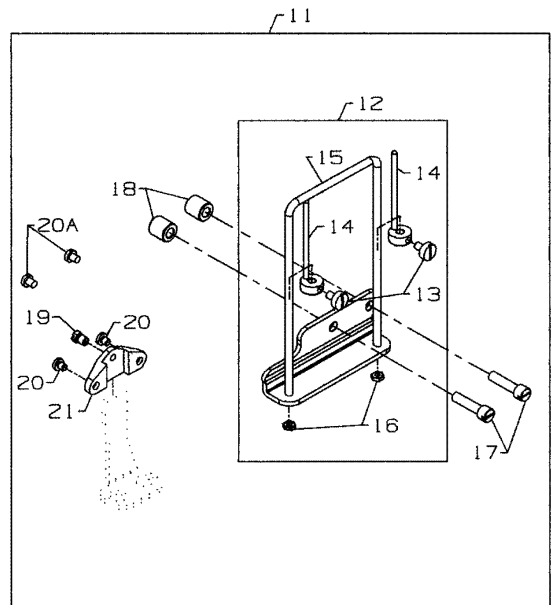
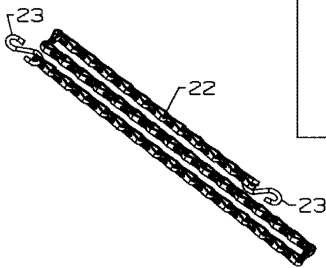
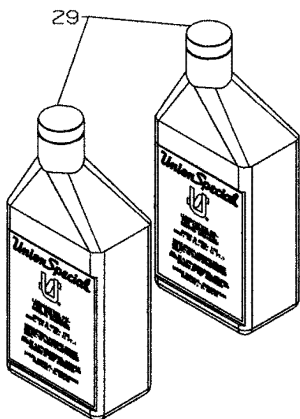
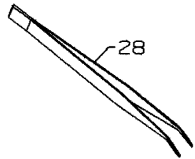
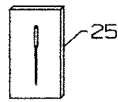
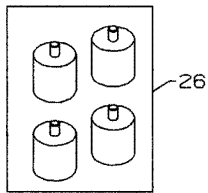
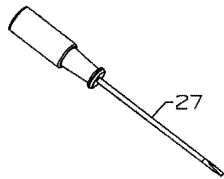
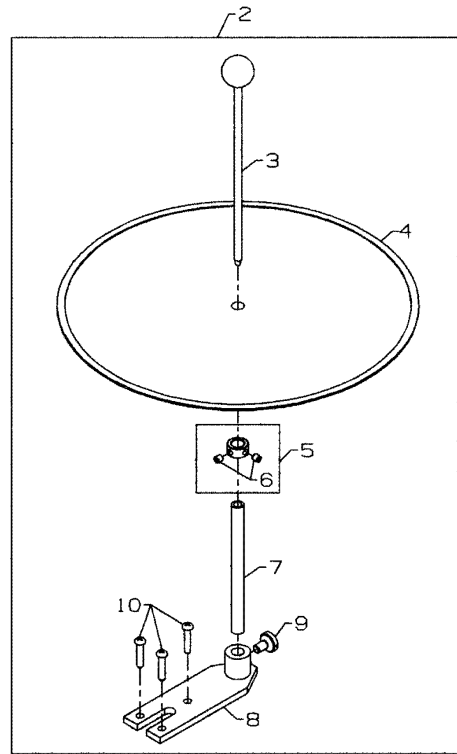
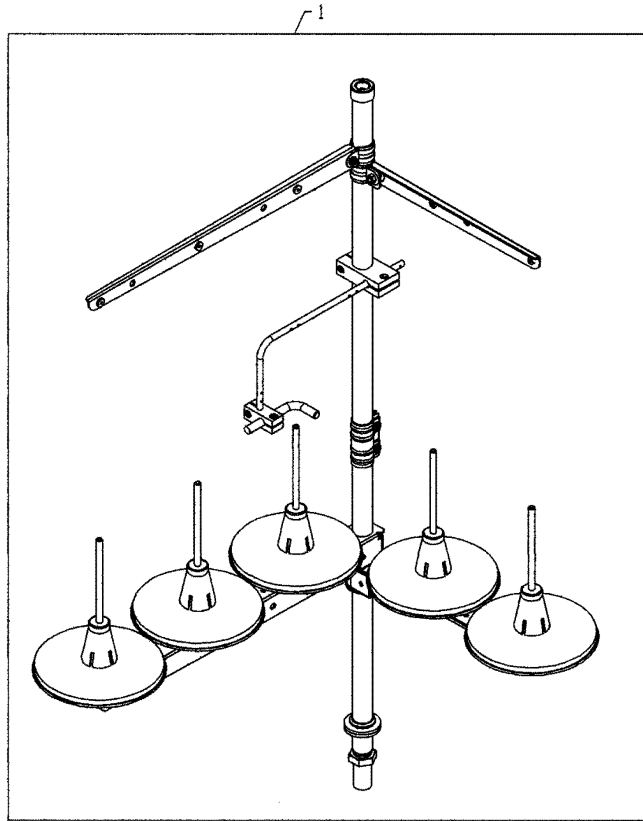

ACCESSORIES

Ref. No.	Part No.	Description	Amt. Req.
1.	11969557	Thread Stand	1
2.	29480AHU	Tape Reel Assembly, for FS322C01, FS332C01	1
3.	50322L	Support Shaft	1
4.	50392C	Tape Disc	1
5.	482C	Collar	1
6.	22894C	Screw	2
7.	50322H	Shaft	1
8.	50364A	Holder	1
9.	22728	Thumb Screw	1
10.	90561K	Wood Screw	3
11.	29480ASR	Strip Tension Kit, for FS322C01, FS332C01	1
12.	23439L	Tension Assembly	1
13.	188D	Screw	2
14.	23439F	Adjustable Pin	2
15.	51-651BLK	Guide	1
16.	907	Nut	2
17.	SS6151920SP	Screw	2
18.	50392D	Spacer	2
19.	22852G	Screw	1
20.	SS7110510SP	Screw	2
20A.	25CC	Screw	2
21.	23432B	Folder Clamp	1
22.	421D34	Chain	1
23.	660-264	S-Hook	2
24.	TT17	Wrench, for FS322E12, FS332E12, FS335E41, FS335E42.....	1
25.	128GBS075/029	Needles (package of 10)	1
26.	35095B	Isolator	4
27.	G21201	Screw Driver, for needle head	1
28.	660-240	Thread Tweezer	1
29.	28604R	Oil (1 pint)	2

From the library of: Diamond Needle Corp



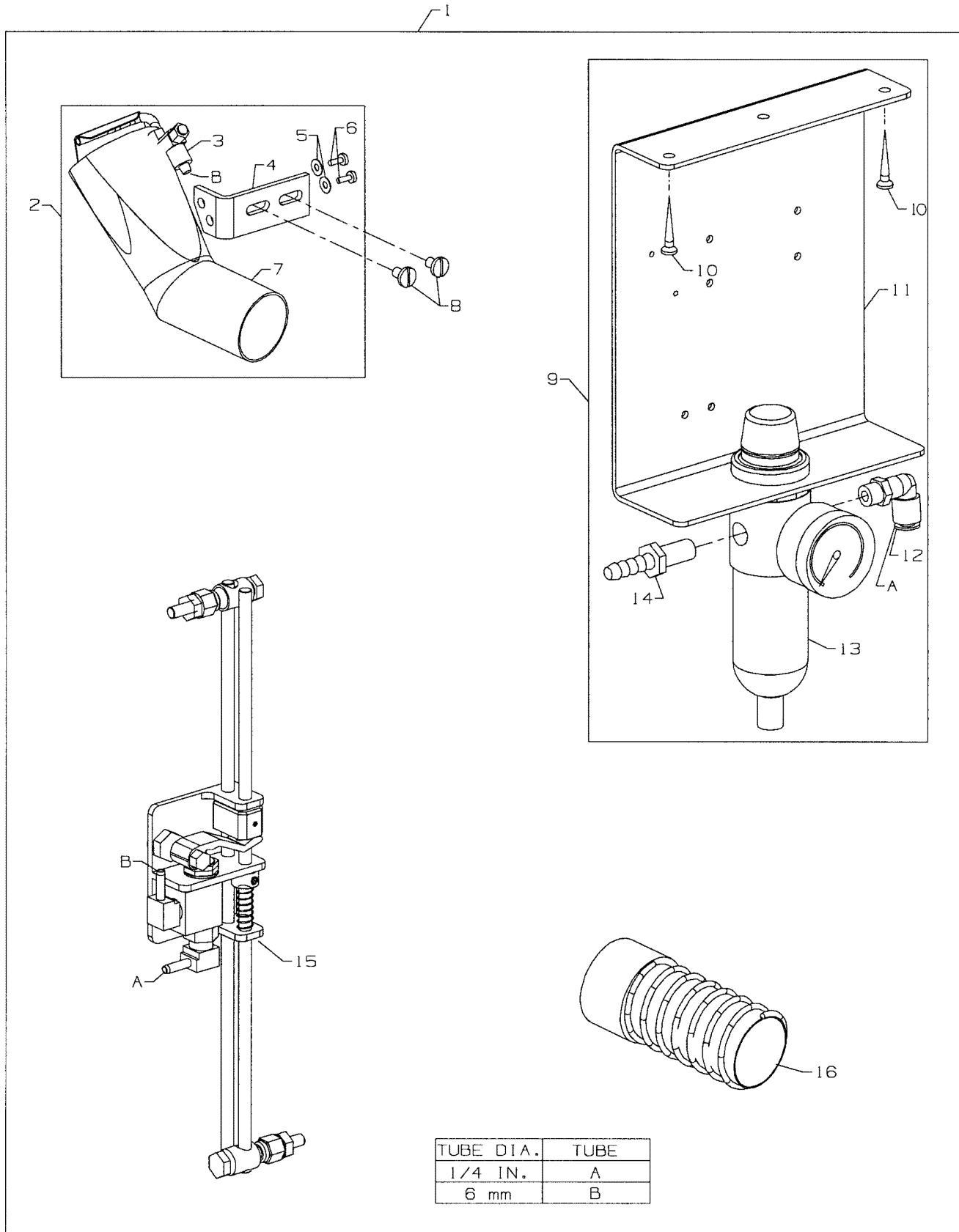

From the library of: Diamond Needle Corp



VACUUM TUBE ASSEMBLY AND PNEUMATIC CONTROL (EXTRA SEND CHARGE)
FOR
FS322E12 & FS332E12

Ref. No.	Part No.	Description	Amt. Req.
1.	29480WR2	Pneumatic Waste Removal Kit	1
2.	50394AH	Vacuum Tube Assembly	1
3.	999-175DA	Fitting	1
4.	50373CR1	Bracket	1
5.	41358	Washer	2
6.	J87J	Screw	2
7.	50373DJ	Tube, for vacuum	1
8.	88D	Screw	2
9.	29480ASU	Pneumatic Control Kit	1
10.	90561K	Wood Screw	2
11.	99683CP	Mounting Bracket	1
12.	671F81A	Elbow Fitting - 6mm x 1/2" NPT	1
13.	671FD42	Filter/Regulator Assembly	1
14.	671F88	Barb Fitting	1
15.	29480ARN	Treadle Switch Assembly	1
16.	99675QB800	Spiral Plastic Hose	1

From the library of: Diamond Needle Corp



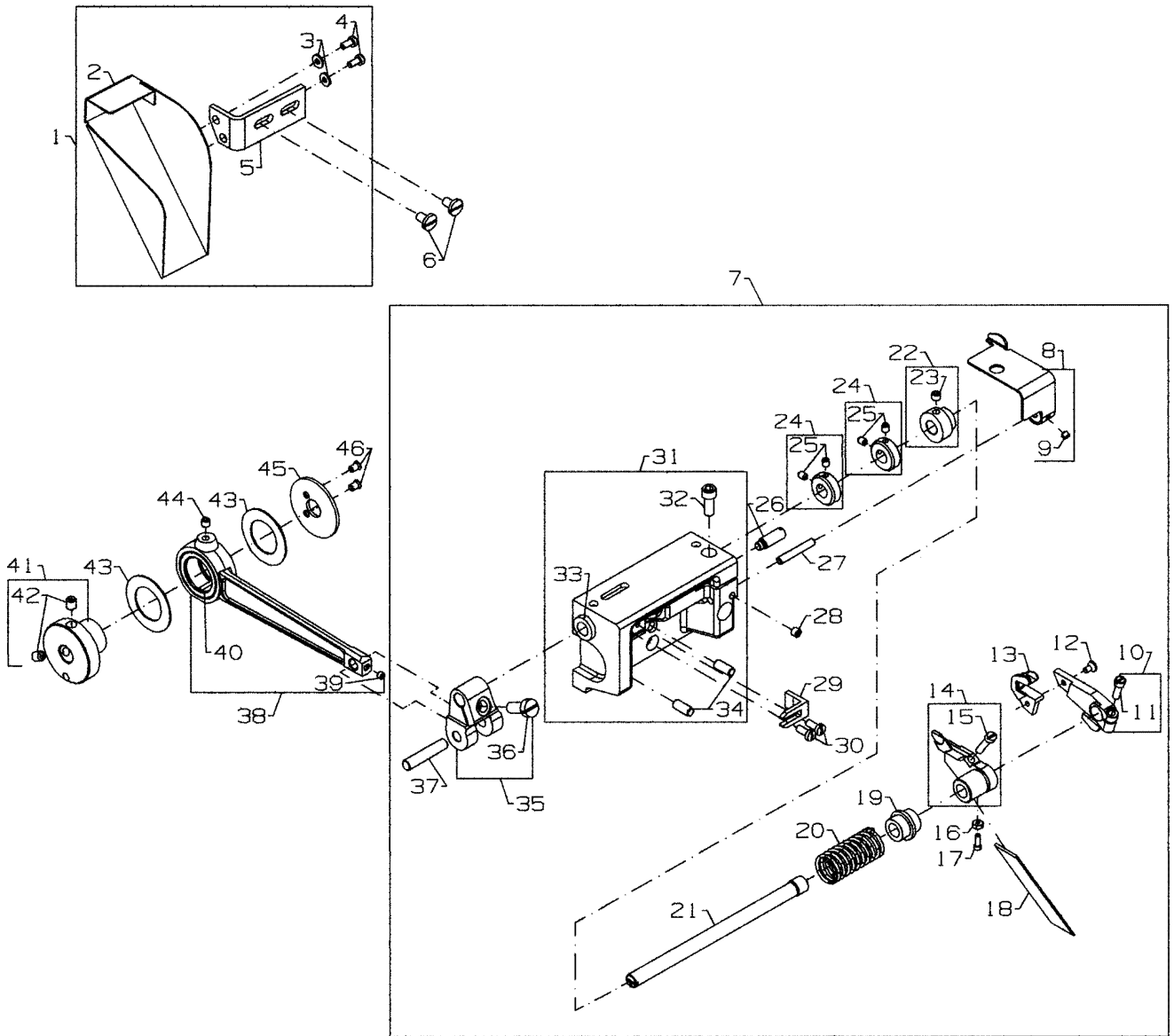

UNDER BED THREAD TRIMMER
FOR
FS322E12 & FS332E12

Ref. No.	Part No.	Description	Amt. Req.
1.	50394AK	Chip Chute Assembly	1
2.	50378U	Chip Chute	1
3.	41358	Washer	2
4.	J87J	Screw	2
5.	50373CR1	Bracket	1
6.	88D	Screw	2
7.	50349B	Undertrimmer Assembly	1
8.	50373DF	Edge Guide	1
9.	22743	Screw	1
10.	34771PA	Upper Knife Holder	1
11.	22729	Screw	1
12.	99316G	Screw	1
13.	34770AH	Upper Knife	1
14.	34750CA	Lower Knife Holder	1
15.	22729E	Screw	1
16.	51250C	Nut	1
17.	22797	Screw	1
18.	34749A	Lower Knife	1
19.	50373D	Collar	1
20.	97010D	Spring	1
21.	50373B	Shaft	1
22.	50373E	Collar	1
23.	22894W	Screw	1
24.	34334D	Thrust Collar	2
25.	22565C	Screw	4
26.	99364	Screw	1
27.	50373DE	Undertrimmer Housing	1
28.	96531	Pin	2
29.	99371G	Screw	1
30.	50373A	Bushing, left	1
31.	50373G	Bracket	2
32.	22585	Screw	1
33.	136	Screw	1
34.	50373DH	Lever Clamp	1
35.	50373K	Link Pin	1
36.	999-313N	Needle Bearing	2
37.	22894E	Screw	1
38.	22894Y	Screw	1
39.	99371G	Screw	1
40.	50373CB	Eccentric, for knife drive	1
41.	22894AD	Screw	2
42.	50373CD	Washer	2
43.	50368AA	Connecting Arm, for knife drive	1
44.	999-313F	Needle Bearing	1
45.	22894W	Screw	1
46.	50373CC	Retaining Plate	1
47.	22766	Screw	2

From the library of: Diamond Needle Corp



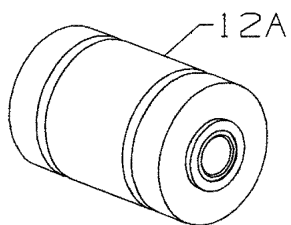
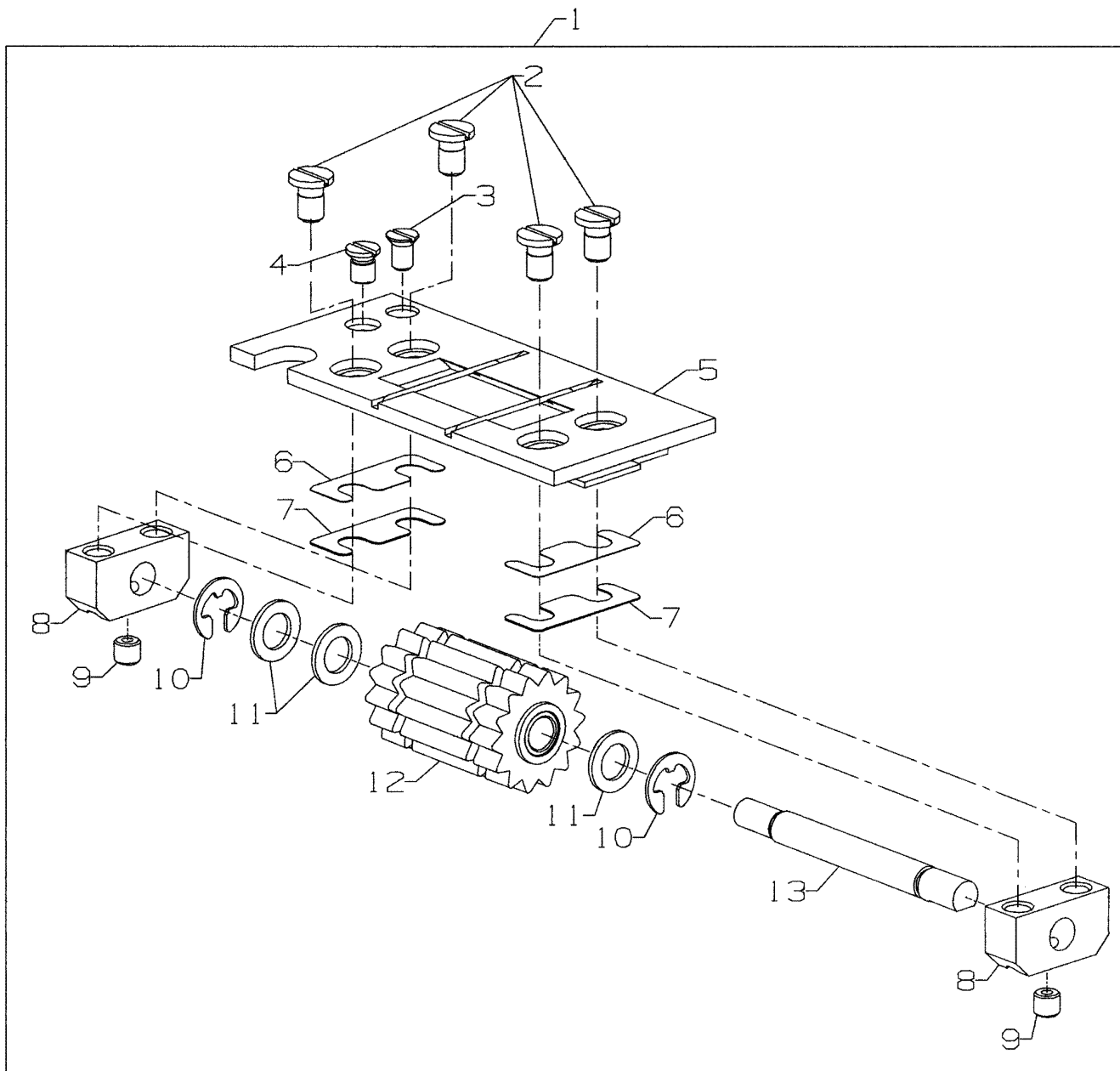

LOWER ROLLER ASSEMBLY
FOR
FS335E41 & FS335E42

Ref. No.	Part No.	Description	Amt. Req.
1.	29476PV	Lower Roller Assembly, for styles FS335E41	1
-	29476PJ	Lower Roller Assembly, for styles FS335E42	1
2.	376	Screw	4
3.	AS22D	Screw	1
4.	SS1110710SP	Screw	1
5.	50378E	Feed Plate	1
6.	C50078AF5	Shim	2
7.	C50078AF10	Shim	2
8.	C50078U	Bearing Block	2
9.	22894W	Set Screw	2
10.	660-330	Retaining Ring	2
11.	6042A	Washer	3
12.	50375D	Puller Roller, for styles FS335E41	1
12A.	C50076	Lower Roller (smooth), for styles FS335E42.....	1
13.	C50074	Pin	1

From the library of: Diamond Needle Corp



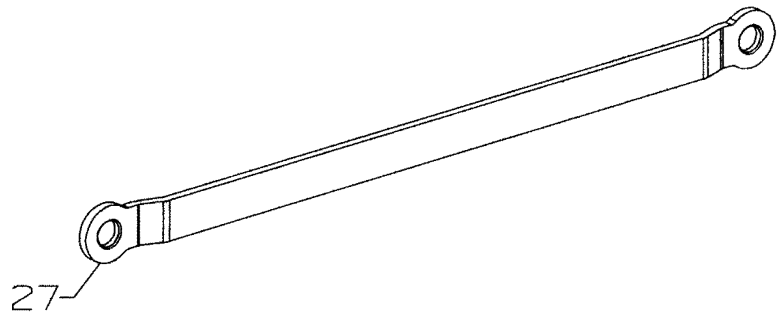
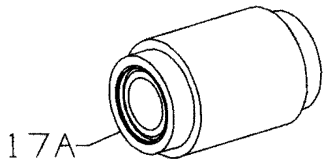
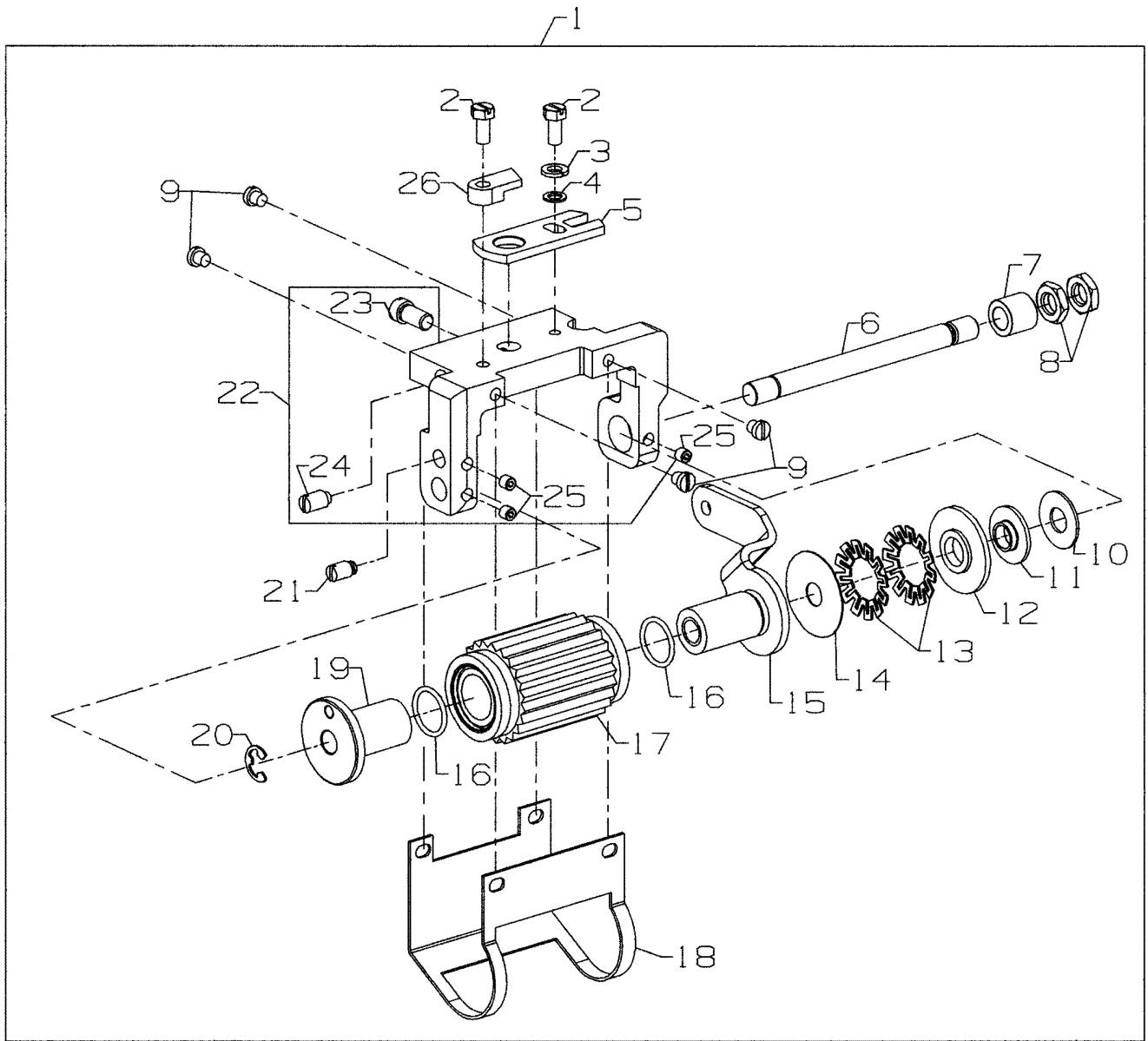

From the library of: Diamond Needle Corp



UPPER ROLLER ASSEMBLY
FOR
FS335E41 & FS335E42

Ref. No.	Part No.	Description	Amt. Req.
1.	29476UW	Upper Roller Assembly, for styles FS335E41	1
-	29476ST	Upper Roller Assembly, for styles FS335E42	1
2.	SS9111010SP	Hex Screw	2
3.	WS0510002KP	Lock Washer	1
4.	53634C	Washer	1
5.	34778D	Guide Plate	1
6.	34774	Shaft	1
7.	34778A	Bushing	1
8.	11638M	Stud Nut	2
9.	SS7110410SP	Screw	4
10.	C50077K	Washer	1
11.	34778C	Bushing	1
12.	50377AE	Disc	1
13.	661-261	Cup Spring	2
14.	50386B	Washer	1
15.	50377H	Lever Assembly	1
16.	661-149	"O" Ring	2
17.	50375Y	Roller Assembly, for styles FS335E41	1
17A.	50375V	Roller Assembly (smooth), for styles FS335E42	1
18.	50377AC	Roller Guard	1
19.	50377AD	Bushing	1
20.	96278	"E" Ring	1
21.	22892C	Shoulder Screw	1
22.	50377AJ	Feed Roller Yolk Assembly	1
23.	SS6151220SP	Screw	1
24.	SS8151150SP	Screw	1
25.	SS8110422TP	Set Screw	3
26.	50377AL	Stop Lever	1
27.	50355AS	Connector, for Presser Foot Lift	1

From the library of: Diamond Needle Corp



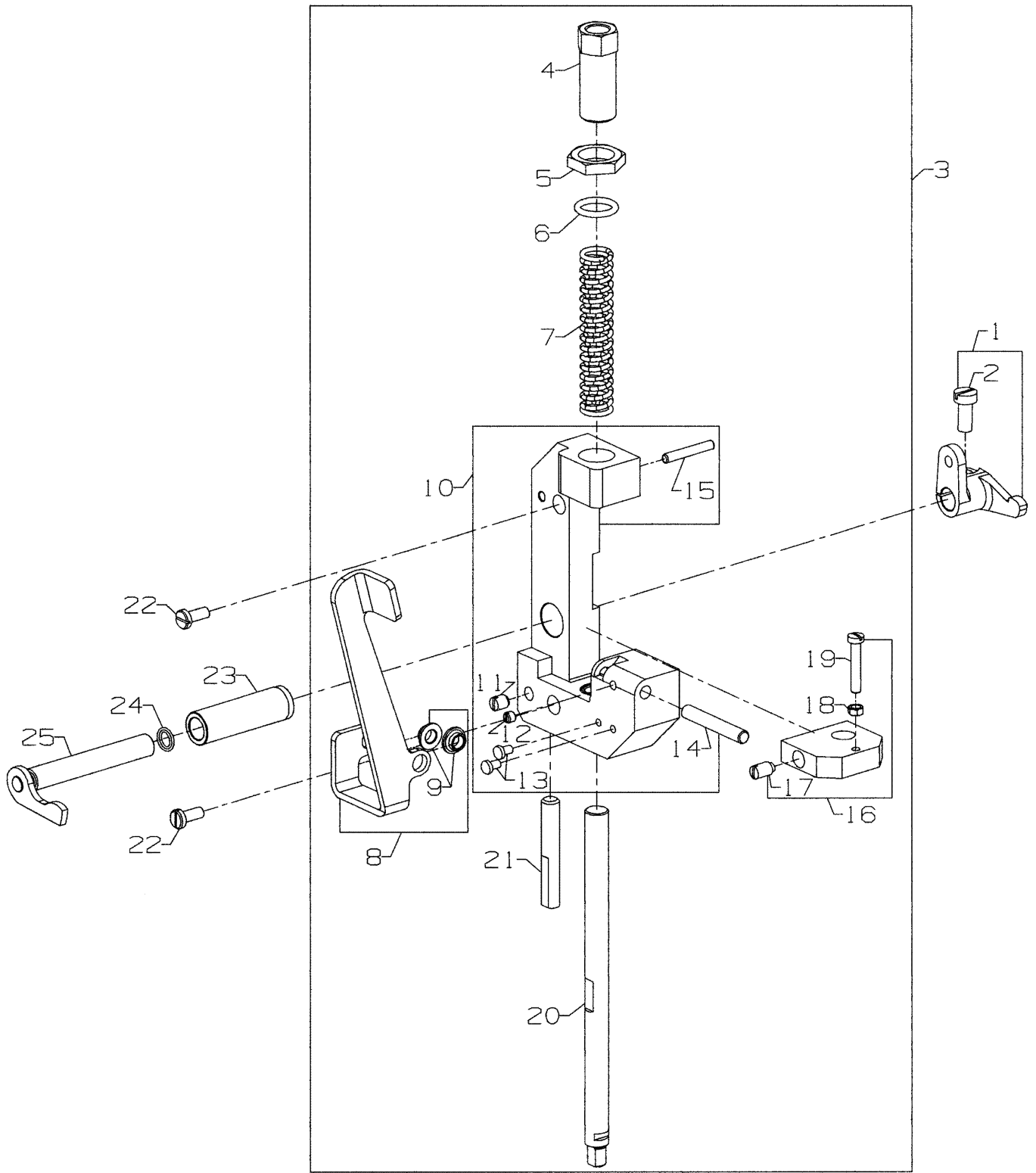

From the library of: Diamond Needle Corp



PULLER LIFTER ASSEMBLY
FOR
FS335E41 & FS335E42

Ref. No.	Part No.	Description	Amt. Req.
1.	50377VA	Lever, lifter front	1
2.	SS6151440SP	Screw	1
3.	29476UX	Puller Lifter Assembly	1
4.	59477	Regulator	1
5.	35733G	Nut	1
6.	660-212	"O" Ring	1
7.	50377L	Spring	1
8.	50377C	Lever, lifter	1
9.	50344AT	Bushing	2
10.	50377D	Bracket, for roller lifter	1
11.	SS8150710SP	Set Screw	1
12.	SS8120410SP	Set Screw	1
13.	50337AM	Bumper	2
14.	50377AF	Pin	1
15.	96529	Pin	1
16.	50377M	Lifter	1
17.	SS8151150SP	Screw	1
18.	NS6110310SP	Nut	1
19.	SS7112420SP	Screw	1
20.	50377AM	Bar, roller presser	1
21.	50377Y	Guide Pin	1
22.	SS6121220TP	Screw	2
23.	50377T	Bushing, lifter link	1
24.	RO068190100	"O" Ring	1
25.	50377G	Lever, Puller Lifter	1

From the library of: Diamond Needle Corp



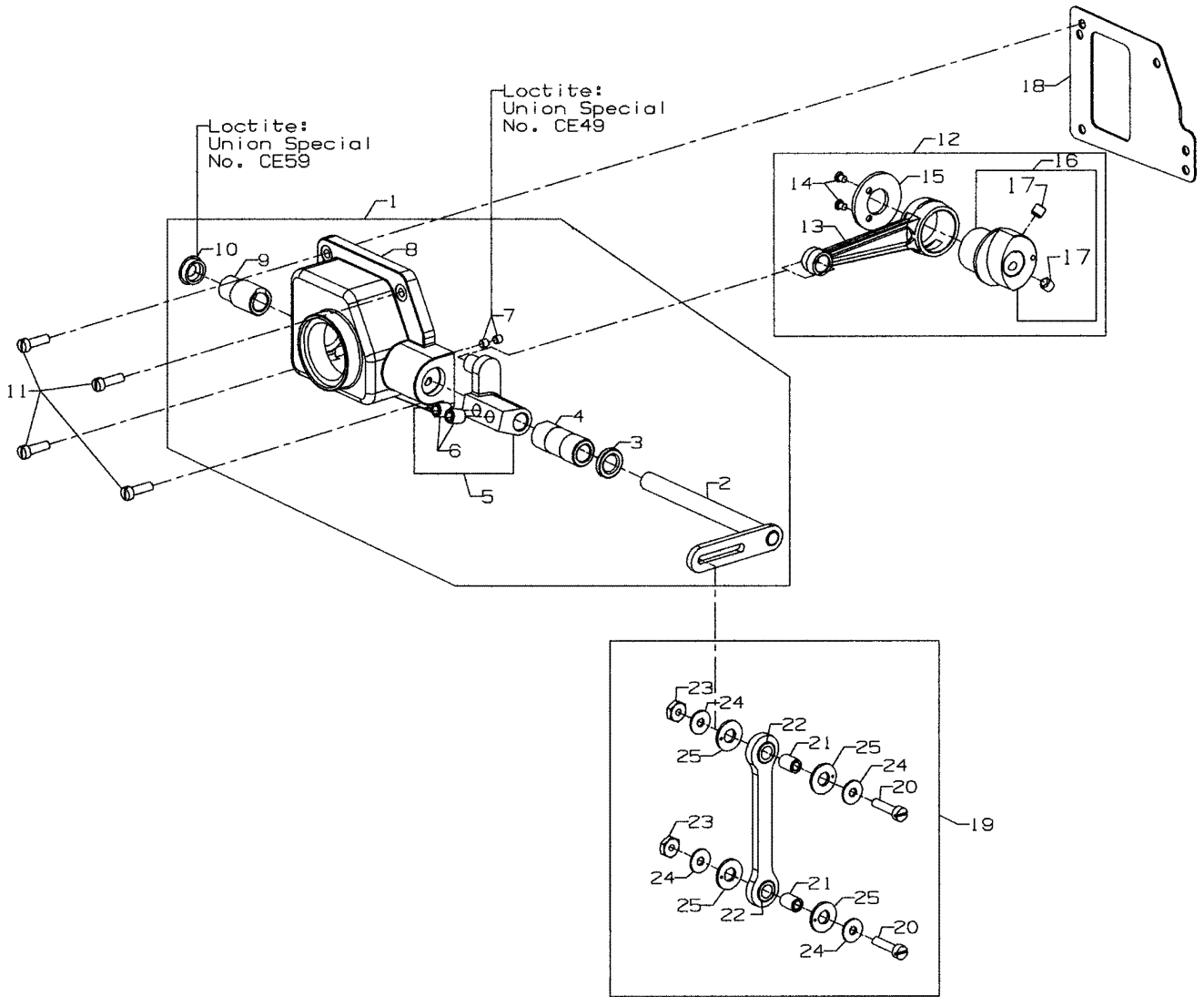

PULLER DRIVE ASSEMBLY
FOR
FS335E41 & FS335E42

Ref. No.	Part No.	Description	Amt. Req.
1.	29476SP	Puller Drive Assembly	1
2.	50377F	Roller Driving Arm	1
3.	660-893	Seal	1
4.	50377S	Bushing	1
5.	50377E	Lever, puller drive	1
6.	SS8110510SP	Set Screw	1
7.	50377U	Housing, puller drive	1
8.	50377P	Bushing	1
9.	TA1450404R0	Rubber Plug	1
10.	SS7121610SP	Screw	4
11.	50377Z	Connecting Rod Eccentric Assembly	1
12.	50377AA	Connecting Rod	1
13.	SS2090620SP	Screw	2
14.	50386	Washer	1
15.	50377AB	Eccentric	1
16.	SS8660612TP	Screw	2
17.	660-1090	Quad Ring	1
18.	50377J	Roller Drive Link Assembly	1
19.	SS6122030SP	Screw	2
20.	50344AP	Bushing, link	2
21.	660-303	Bearing	2
22.	NS6120480SP	Nut	2
23.	WP0501046SC	Washer	4
24.	660-1089	Thrust Washer	4

From the library of: Diamond Needle Corp



NUMERICAL INDEX OF PARTS

<u>Part No.</u>	<u>Page No.</u>	<u>Part No.</u>	<u>Page No.</u>	<u>Part No.</u>	<u>Page No.</u>	<u>Part No.</u>	<u>Page No.</u>
11071602	21	22839C	41, 43	34730H	47	50320T60	57
11071701	21	22840A	51	34749A	67	50321F	13
11550209	19	22841U	43	34750CA	67	50321G	25
11638M	71	22852G	63	34770AH	67	50322AF	13
11843208	27	22875N	19	34771PA	67	50322AG	25
11960002	61	22882E	45	34774	71	50322AJ	25
11960101	61	22892C	71	34778A	71	50322AK	25
11969557	63	22894AD	67	34778C	71	50322AL	25
12124202	17	22894C	33, 43, 63	34778D	71	50322AR	39
128GBS075/029	63	22894E	67	34830LA	51	50322AT	25
136	67	22894P	39	34830MA	51	50322AU	25
13765607	27	22894W	45, 67, 69	35036AB	9	50322H	63
18-1432	35, 37	22894Y	67	35036AZ	39	50322L	63
18-1445	37	23195	57	35036F	39	50323B	33
18-1448	41	23432B	63	35095B	63	50323P	11
18-1470	27	23439F	63	35569J	43	50323R	33
187A	45, 47, 51	23439L	63	35733G	73	50324DB56	53
188D	63	25	53	36271A	17	50324DC64	53
20	43, 45	25CC	63	37-70BLK	41	50325AD	31
201C	53	25D	53	376	69	50325AE	31
21210	53	25S	43	39568J	53	50325AF	31
21371AAE48	59	27-435BLK	57	402	19	50325AJ	31
21371AAG48	61	28604R	63	41071G	43, 45	50326AY	57
22513D	43, 45	29126FW	15	41358	65, 67	50326BL	53
22517	41	29475CG	17	421D34	63	50328	41
22519J	43, 45	29476PJ	69	482C	63	50330BH64	53
22525A	45	29476PV	69	50301AY	45	50330BL16	57
22541A	43	29476RZ	59	50301AZ	41	50330BN12	47
22561	57	29476SP	75	50301BA	41	50330BN16	47
22562	21	29476ST	71	50301BF	41	50330BN48	47
22565	29	29476TC	11	50301BH	41	50330BN8	47
22565C	67	29476TK	21	50301CH	41	50330BP16	47
22565E	47	29476TT	21	50303A	45	50330CC12	51
22571E	27	29476UF	39	50303B	41	50330CC8	51
22571L	9	29476UH	25	50304K	33	50330CD	51
22585	67	29476UJ	31	50304N	33	50330CE16	51
22591A	39	29476UM	35, 37	50305BM	57	50330CF	51
22596H	39	29476US	27	50305BS	53	50330CZ	9
22652B10	29	29476UT	27	50309F	29	50330EE48	51
22653J8	29	29476UW	71	50309K	29	50332A	43, 45
22704	45	29476UX	73	50313	29	50332AC	33
22714C	39	29476VX	43	50313J	29	50332B	43
22716	53	29476VY	45	50313M	29	50332F	43
22716A	57	29480AHU	63	50313P	29	50332S	27
22726	41	29480ARN	65	50314E	29	50332U	9
22728	63	29480ASR	63	50314F	29	50332V	21
22729	67	29480ASU	65	50317B	11	50332W	37
22729D	43, 45	29480AWR	53	50317C	23	50333A	25
22729E	67	29480WR1	61	50318AA56	53, 57	50334AW	35, 37
22738B	51	29480WR2	65	50318AA64	53	50334AX	35, 37
22743	67	34334D	67	50318AE40	47, 51, 57	50334BB	39
22766	67	34393D	27	50318AE56	47, 51, 53, 57	50334BC	39
22799AH	43	34703E1	43	50318Z40	57	50334BD	35, 37
22799B	47, 51	34703F2	43	50320AT	57	50334BE	35, 37
22799M	43	34730A	53	50320BF64	53	50334BH	35, 37



NUMERICAL INDEX OF PARTS

<u>Part No.</u>	<u>Page No.</u>	<u>Part No.</u>	<u>Page No.</u>	<u>Part No.</u>	<u>Page No.</u>	<u>Part No.</u>	<u>Page No.</u>
50334BJ	35, 37	50344E	9	50368T	31	50381B	21
50334J	35	50345U	41	50368V	31	50381E	9
50334V	35, 37	50345W	11	50368W	31	50381F	21
50334Y	35, 37	50346	17	50370F	17	50381G	21
50335	39	50346A	15	50373A	67	50382BB	45
50335A	21, 39	50347C	15	50373B	67	50382CG	43
50335AF	21	50347E	9	50373CB	67	50382CH	43
50335AG	21	50347F	9	50373CC	67	50382CJ	43
50335AH	21	50347G	15	50373CD	67	50382CK	41, 43
50335AK	25	50347J	15	50373CR1	65, 67	50382CL	41
50335AM	35, 37	50347L	9	50373D	67	50382CM	43
50335AN	35, 37	50347P	45	50373DA	31	50382CP	41
50335AS	37	50347R	33	50373DE	67	50382CR	41
50335AW	15	50349B	67	50373DF	67	50382CS	41
50335BA	35, 37	50351A	11	50373DH	67	50382CT	41
50335BB	25	50352	11	50373DJ	65	50382FS	43
50335BD	13	50354F	11	50373E	67	50382FT	45
50335D	39	50354G	11	50373G	67	50382FW	23
50336	43	50354H	9	50373K	67	50382FX	23
50336L	43	50354J	9	50374	25	50382FY	23
50336S	39	50354L	31	50375D	69	50382FZ	23
50336V	37	50355	39	50375V	71	50382GA	23
50336W	41	50355AM	11	50375Y	71	50382GB	23
50336Y	39	50355AN	11	50377AA	75	50382GC	23
50337AM	73	50355AR	21	50377AB	75	50382GK	43
50337H	35, 37	50355AS	71	50377AC	71	50382GL	43
50337J	35	50357AC	43	50377AD	71	50382GM	23
50337K	35	50357AE	17	50377AE	71	50382JB	43
50337L	35, 37	50357AM	33	50377AF	73	50382JR	41
50337M	35	50357AN	33	50377AJ	71	50382T	43, 45
50337P	37	50357AP	21	50377AL	71	50383AC	61
50337R	35	50358U	17	50377AM	73	50383AD	23
50337S	35, 37	50358V	17	50377C	73	50383AE	23
50337T	39	50358W	17	50377D	73	50383F	33
50337U	35, 37	50358X	11	50377E	75	50383G	43
50337Y	37	50360	15	50377F	75	50383L	11
50340D	35, 37	50360B	15	50377G	73	50383M	11
50340E	35, 37	50360E	15	50377H	71	50384	27
50342AX	25	50360F	15	50377J	75	50384A	27
50342BE	13	50360G	15	50377L	73	50384E	41
50342BJ	29	50360H	15	50377M	73	50384K	41
50342BK	29	50363CH	43, 45	50377P	75	50384L	23
50342BP	29	50363CJ	17	50377R	33	50386	75
50342BS	25	50363CK	17	50377S	75	50386B	71
50343A	45	50364A	63	50377T	73	50387	35, 37
50344AH	9	50364M	45	50377U	75	50387S	43
50344AJ	9	50364P	45	50377VA	73	50389B	53
50344AM	29	50366	17	50377Y	73	50391	13
50344AP	75	50366A	17	50377Z	75	50392AB	9
50344AS	9	50366B	17	50378E	69	50392AE	17
50344AT	73	50368A	31	50378T	45	50392AU	17
50344ABC	9	50368AA	67	50378U	67	50392AV	19
50344BE	9	50368AB	9	50380KA	41	50392AW	17
50344BF	9	50368E	31	50380LA	41	50392AX	17
50344BU	9	50368H	45	50381	21	50392AY	17

From the library of: Diamond Needle Corp



NUMERICAL INDEX OF PARTS

<u>Part No.</u>	<u>Page No.</u>	<u>Part No.</u>	<u>Page No.</u>	<u>Part No.</u>	<u>Page No.</u>	<u>Part No.</u>	<u>Page No.</u>
50392AZ	17	50393JY	11	660-1046	53	96671	47
50392BC	19	50393JZ	11	660-1062	25	97010D	67
50392C	63	50393KF	27	660-1087	13	97109	47, 51
50392D	63	50393KH	27	660-1089	75	97127	45
50392G	47, 51	50393KM	27	660-1090	75	99316G	67
50392G	53, 57	50393W	43, 45	660-206	39	99364	67
50392S	17	50394AF	11	660-212	23, 73	99371G	67
50392T	17	50394AH	65	660-220	39	99373A	51
50392V	17	50394AK	67	660-240	63	99675QB800	65
50392W	19	50397A16	57	660-264	63	99682XC	23
50392X	19	50397A48	57	660-283A	19	99682XCA	23
50392Y	19	50397C	57	660-303	75	99682XCB	23
50392Z	19	50634G	39	660-330	69	99683CP	65
50393-120	27	50642	29	660-455	29	998-358F	27
50393-140	27	50674	39	660-739	15, 21	999-175DA	65
50393-170	27	50692G	19	660-893	29, 75	999-216C	43
50393-27	27	51-651BLK	63	660-934	25	999-313F	67
50393-40	27	51250C	67	660-939	41	999-313N	67
50393-407	27	51430F	47, 51	660-969	39	AS22D	69
50393-447	27	51492	33	660-974	43	B1647704000A	35
50393-70	27	51493AF	53	660-979	29	B1647704000A	37
50393EB	27	51959B	33	660-980	11, 39	B3101804000	19
50393EU	23	51959D	33	661-149	71	B3103804000	19
50393EW	23	51959E	47	661-259B	11	B3112704000	19
50393EX	27	51959L	33	661-261	13, 71	B3120352000	19
50393EY	9	52730T	51	661-262	13	B3120704000	19
50393FR	27	52830G	47, 51	661-35	39	B3121804000	19
50393FS	27	52864W	45	661-96	39	B3126012000	19
50393FT	27	52888B	21	666-330	19	B3530555000	23
50393FU	9	52958D	33	667J33	29	C50044E	17
50393FV	27	53634C	71	671D41	65	C50056B	21
50393GB	27	53678N	15	671D42	65	C50074	69
50393GD	27	56392G	19	671F81A	65	C50076	69
50393GE	9	56392H	19	671F88	65	C50077K	71
50393GG	59	56392L	19	671FD42	65	C50078AF10	69
50393GK	59	56392M	19	73B	51	C50078AF5	69
50393GP	59	56392R	19	77L	45	C50078U	69
50393GS	59	57830A	57	79633	57	CE27	11
50393H	43	57844	17	80	45	CE49	21
50393HB	23, 43	57864B	53	87	47, 51, 53, 57	CE59	11
50393HH	17	57865	19	88D	65, 67	CE63	11, 29, 41
50393HJ	27	57892K	19	90561K	61, 63, 65	CE66	21
50393HK	27	57WD	47, 51	907	63	CL21A	9
50393HL	27	59477	73	91	47, 51, 53, 57	CO67D	41
50393HN	27	6-25-55	53, 57	94	43, 45	CQ202000000	59
50393HR	27	6042A	69	95956	51	CQ25220000	11
50393HS	11	605	47, 51, 57	95978	41	G21201	63
50393HU	43	605A	17	96162B	15	G50-266	57
50393HW	11	61351C	15	96278	71	G57730GB	53
50393JC	59	652C16	17	96529	73	G57730GC	53
50393JD	59	660-1014	21	96531	67	G57730GD	53
50393JP	11	660-1020	43	96532	47, 51	G65-134	57
50393JW	11	660-1043	13	96651	53	G65-181	47, 51

From the library of: Diamond Needle Corp



NUMERICAL INDEX OF PARTS

<u>Part No.</u>	<u>Page No.</u>	<u>Part No.</u>	<u>Page No.</u>	<u>Part No.</u>	<u>Page No.</u>
J 8 7 J	6 5 , 6 7	SS6110610TP	21, 33	SS8660612TP	27, 29,
L A 4 5 2	2 3	SS6110650TP	35, 37	SS8660612TP	33, 35,
NS1160420SP	19	SS6120930TP	43	SS8660612TP	37, 75
NS6090310SP	61	SS6121010SP	11, 21	SS8661012TP	13, 25, 39
NS6110310SP	27, 73	SS6121212TP	41	SS8681412TP	13
NS6110420SP	19	SS6121220TP	73	SS9090410TP	31
NS6110530SP	37	SS6122030SP	75	SS9090420TP	31
NS6120480SP	75	SS6151220SP	71	SS9090640SP	15
NS6150310SP	21	SS6151440SP	73	SS9111010SP	33, 71
NS6620320SP	23	SS6151812TP	27	SS9151740CP	21
NS6680410SP	15	SS6151920SP	21, 63	TA0620504R0	43
PS0160042KH	59	SS6153040SP	21	TA0750404R0	43
PS0400142KH	9	SS7060310SP	17, 31,	TA0750404RO	43
RE0500000K0	21	SS7060310SP	33	TA075404R0	39
R M 2 8 7 1 B	2 7	SS7080510TP	15, 17	TA1050504R0	23
RO0681190100	35	SS7080520SP	11	TA1050504RO	23
RO068190100	21,	SS7090520SP	19	TA1100604R0	23, 43
RO068190100	37, 73	SS7090530SP	35, 37	TA1450404R0	75
RO681190100	35	SS70906105SP	17	T T 1 7	6 3
S5060410TP	57	SS7090610SP	17, 35,	WP0330501SP	33
SD0380551SL	33	SS7090610SP	37	WP0501046SC	75
SD0630275SP	33	SS7090850SP	43	WP0531000SD	59
SD0640323TP	23	SS7090910TP	17	WP0742016SP	15
SD0790303SP	21	SS7091110TP	47, 51,	WS0510002KP	17, 71
SD1000801SH	15	SS7091110TP	53, 57	WS0631510KP	27
SP0550271TP	35	SS7092110TP	33	WZ0640200KP	33
SQ1110401MZ	9	SS7110410SP	71	WZ0641510KP	23
SQ1110402MZ	27	SS7110510SP	63		
SS1110640SL	23	SS7110910TP	15		
SS1110710SP	69	SS7111120TP	11, 13		
SS1121010SP	17	SS7112420SP	73		
SS2090620SP	75	SS7120640SP	17, 23		
SS4080620TP	11	SS7120710SP	17, 27, 43		
SS4090615SP	59	SS7120910SP	29		
SS4090815SP	17, 27	SS7121410TP	15, 19		
SS4091015SP	27	SS7121610SP	75		
SS4120615SP	17, 19, 23,	SS7150740SP	41		
SS4120615SP	41, 59	SS7660520SP	13, 25		
SS4120915SP	17, 19, 23	SS7681410TP	13		
SS4121015SP	43	SS8080310TP	47, 53, 57		
SS4121215SP	23, 35	SS8080410TP	17		
SS4121615SP	23	SS8090710SP	9, 35		
SS4151415SP	43	SS8110422TP	11, 15,		
SS5060410SP	51, 53	SS8110422TP	21, 31,		
SS5060410TP	57	SS8110422TP	35, 37,		
SS5090610SP	37	SS8110422TP	39, 71		
SS5091020SP	61	SS8110510SP	75		
SS6060440TP	33, 47,	SS8120410SP	73		
SS6060440TP	51	SS8150710SP	73		
SS6080410SP	33	SS8151150SP	71, 73		
SS6090440SP	11	SS8660410SP	25		
SS6090620SP	11	SS8660512TP	15		
SS6091022TP	35	SS8660612TP	13, 15, 25,		



Union Special Corporation
Corporate Office
One Union Special Plaza
Huntley, IL 60142
Phone: 847•669•5101
Fax: 847•669•4454

Union Special GmbH
European Distribution Center
Raiffeisenstrasse 3
D-71696 Möglingen, Germany
Tel: 49•07141•247•0
Fax: 49•07141•247•100

JUKI CORPORATION
INTERNATIONAL SALES DIVISION
8-2-1, KOKURYO - CHO,
CHOFU-SHI, TOKYO 182, JAPAN
PHONE: 03(3430)4001~5
FAX: 03(3430)4909 . 4914 . 4984



JUKI
Union Special